

**HIGH QUALITY**

**HIGH TOLLERANCE**



**A COMBINATION OF PERFORMANCE AND CONVENIENCE**

## 01. LIST OF CONTENTS

SECTION	PAG.	COMPONENT
01.	2	LIST OF CONTENTS
02.	3	FEATURES AND GENERAL DESCRIPTION
03.	4	TECHNICAL FEATURES
04.	4	OPERATION
05.	5	HOW TO JOIN/SEPARATE OUTLETS
06.	6	HOW TO ORDER
07.	6	OVERALL DIMENSIONS
08.	7	VISUAL PIN
09.	7	INDUCTIVE SENSOR CONTROL
10.	7	INDUCTIVE SENSOR CONTROL (ATEX)
11.	8	SHUT OFF VALVE EV-2
12.	8	PRESSURE INDICATORS
13.	8	INLET ACCESSORIES
14.	9	INLET FITTINGS
15.	9	OUTLET FITTINGS

DPL  
MONOBLOCK  
PROGRESSIVE  
DIVIDERS

MONITORING  
ELEMENTS

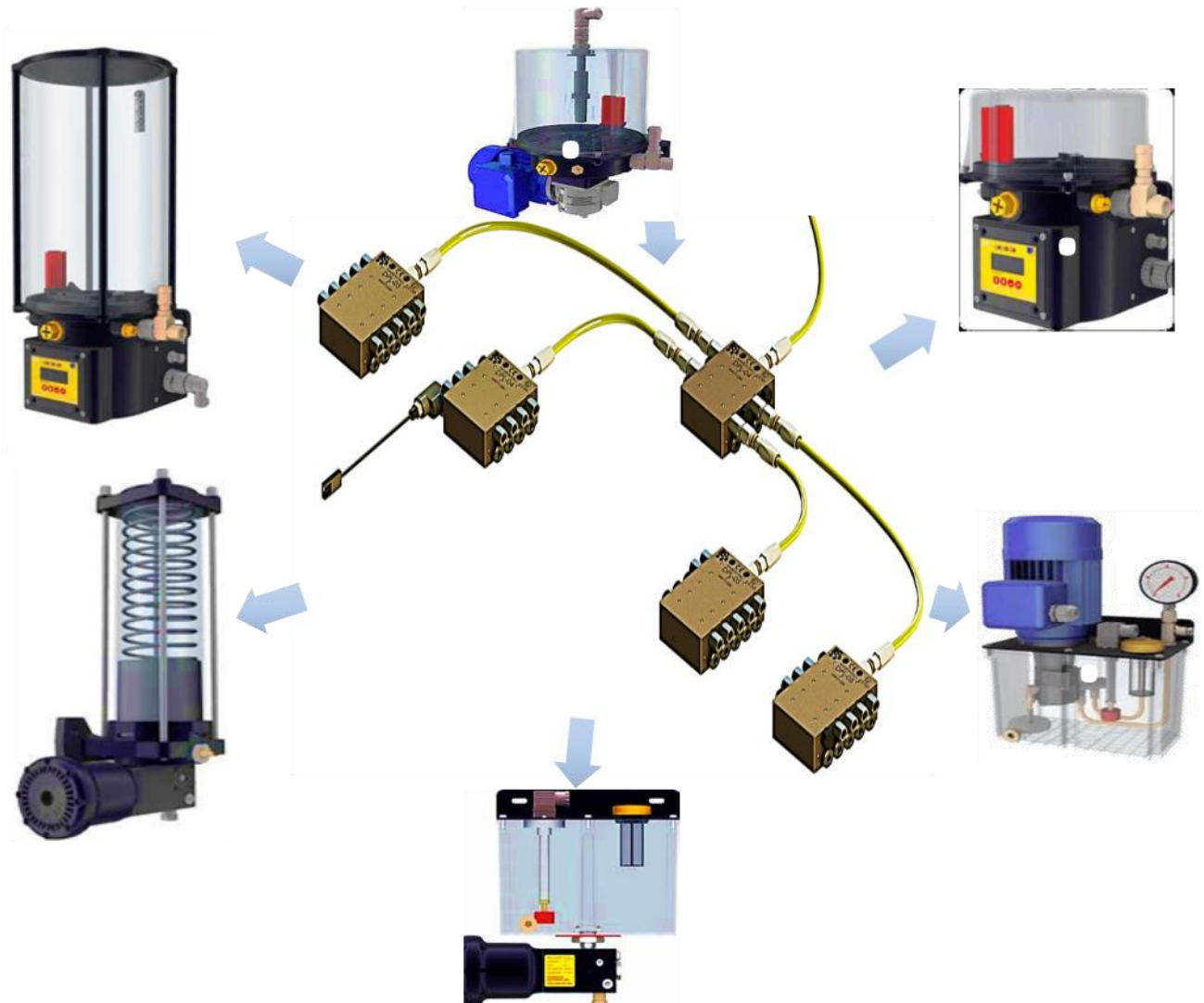
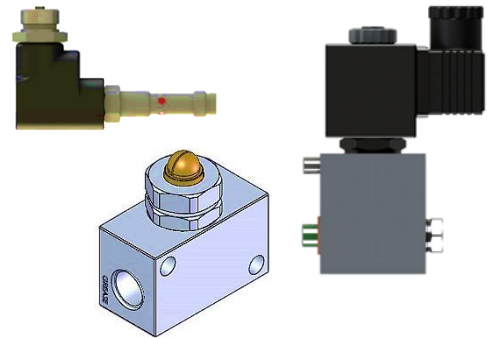



## 02. FEATURES AND GENERAL DESCRIPTION

**DPL**

is the lubrication system which, by mean of a progressive movement of pistons, measures out and deliveries lubricant to one or more friction points. Each piston works in series with the one before it and the one after it and therefore malfunctioning of one of these can cause hydraulic block. This happens also in case of a plug inside the system (divider, hose, lubrication point) or when outlet not being used anymore is plugged. Is it possible to monitor the functioning of the whole system just checking the movement of one piston.

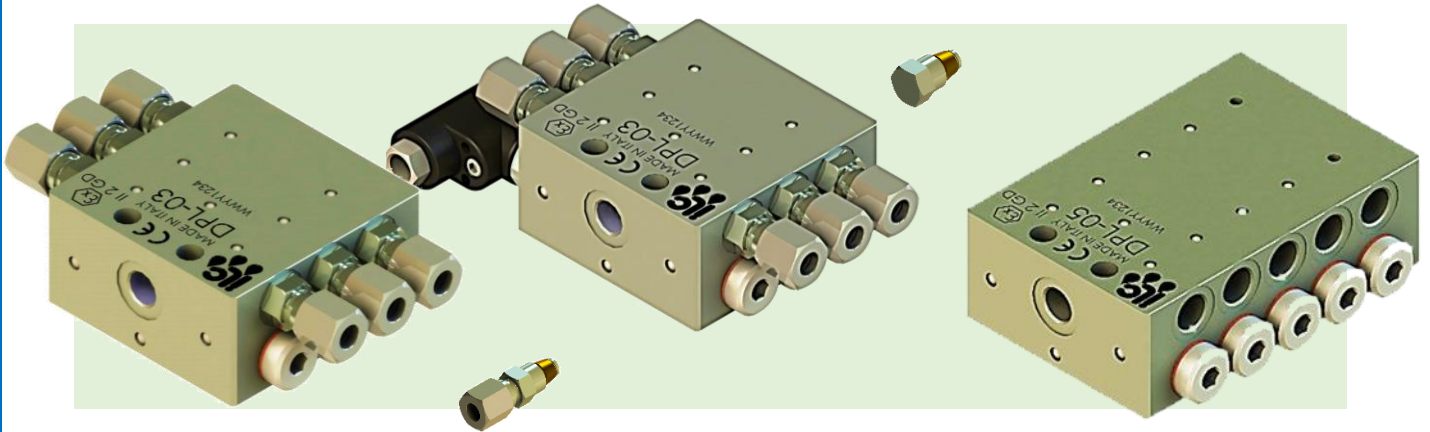

### DPL PROGRESSIVE DIVIDERS ADVANTAGES

STANDARD INLET CHECK VALVE

EASIER CONFIGURATION WITH LESS PISTONS

EVEN POSSIBLE TO CLOSE ONE OF THE LAST TWO OUTPUTS

TWO DIFFERENT WAYS TO JOIN OUTLETS

PLUG FOR CONVEYING IN THE NEXT OUTPUT

SEPARATION SCREW FOR ONE SINGLE OUTLET

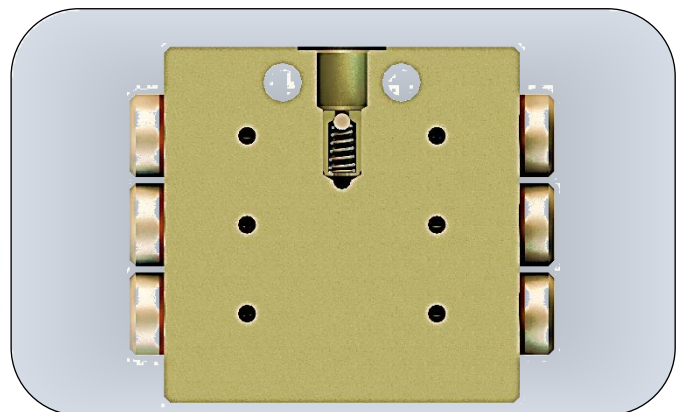

### 03. TECHNICAL FEATURES

Operating pressure	<ul style="list-style-type: none"> <li>From 15 to 300 Bar</li> </ul>
Lubricants (at minimum operating temperature)	<ul style="list-style-type: none"> <li>Mineral oil minimum 46 cSt or Grease maximum NLGI-2</li> </ul>
Operating temperature	<ul style="list-style-type: none"> <li>From -40 °C to 110 °C</li> </ul>
Discharge (for outlet)	<ul style="list-style-type: none"> <li>200 mm<sup>3</sup>/cycle</li> </ul>
Inlet port	<ul style="list-style-type: none"> <li>1/8 BSP</li> </ul>
Check valve	<ul style="list-style-type: none"> <li>Standard in the inlet</li> </ul>
Outlet port	<ul style="list-style-type: none"> <li>M10x1</li> </ul>
Outlets	<ul style="list-style-type: none"> <li>from 6 to 20</li> </ul>
Piston cycles	<ul style="list-style-type: none"> <li>Max 350/min</li> </ul>
Coating	<ul style="list-style-type: none"> <li>Zinc-Nickel plated</li> </ul>
Marking	<ul style="list-style-type: none"> <li>ATEX II GD - CE</li> </ul>
Metering devices	<ul style="list-style-type: none"> <li>Steel, Zn-Ni plated (free of Cr-VI)</li> </ul>

### 04. OPERATION

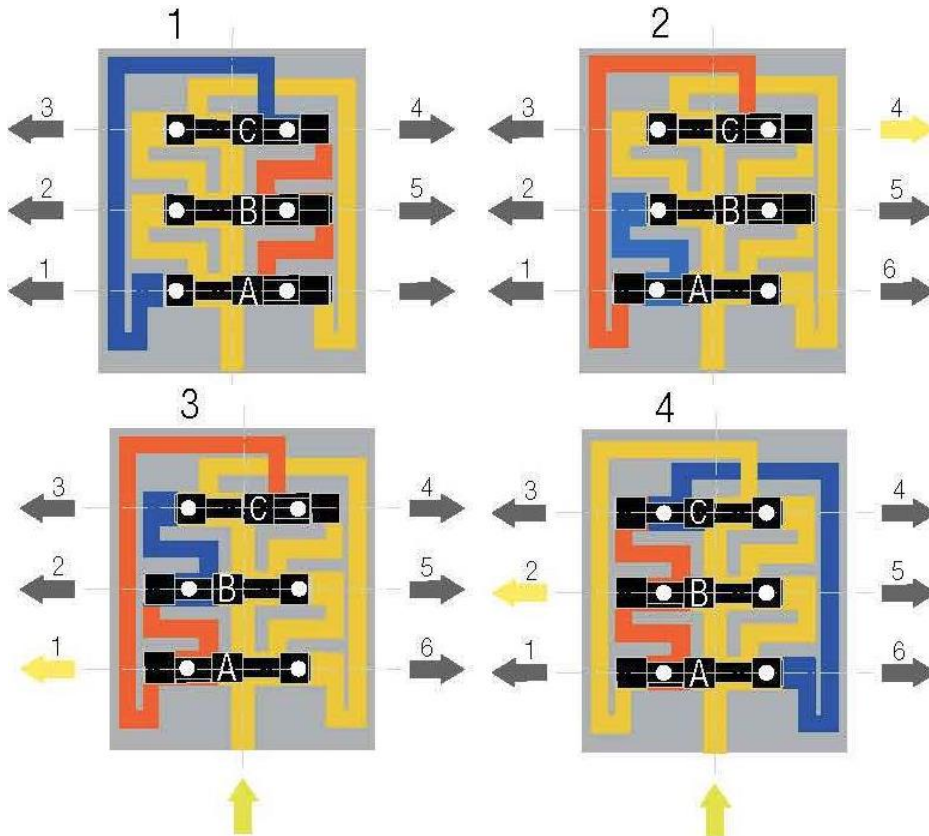

1. Supply pressure moves piston "A" left while holding pistons "B" and "C" fixed through inner holes

2. A measured quantity of lubricant is discharged from the port "4". Piston "A" is at limit and opens the hole to allow the pressure to reach the right end of piston "B"

3. A measured quantity of lubricant is discharged from the port "1". Piston "B" is at limit and opens the hole to allow the pressure to reach the right end of piston "C"

4. A measured quantity of lubricant is discharged from the port "2". Piston "C" is at limit and opens the hole to allow the pressure to reach the right end of piston "A". And so on...

## 05. HOW TO JOIN/SEPARATE OUTLETS

One separation dowel (FIG.1) divides the lubricant through the two outlets. In order to have just one outlet with the double discharge remove the dowel and close one of the outlet with the plug (FIG.2).

**UNI5927-M4x8**

**SEPARATION DOWEL**

FIG.1

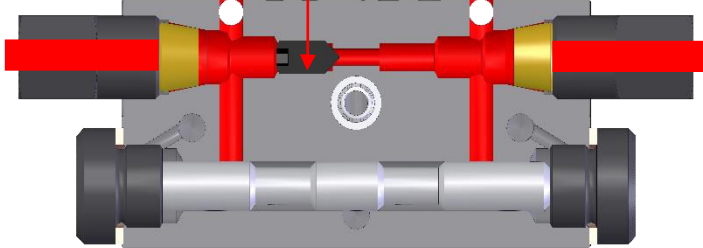
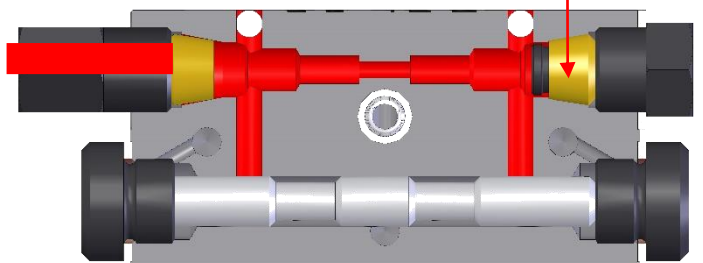

FIG.2

**05.026.0**

**PLUG**



By mean of the plug A73.096032 lubricant will be conveyed in the next outlet. Combination of plugs 05.026.0 and A73.096032 and separation dowel UNI5927-M4x8 allow to have a great flexibility in dosing and number of outlets.

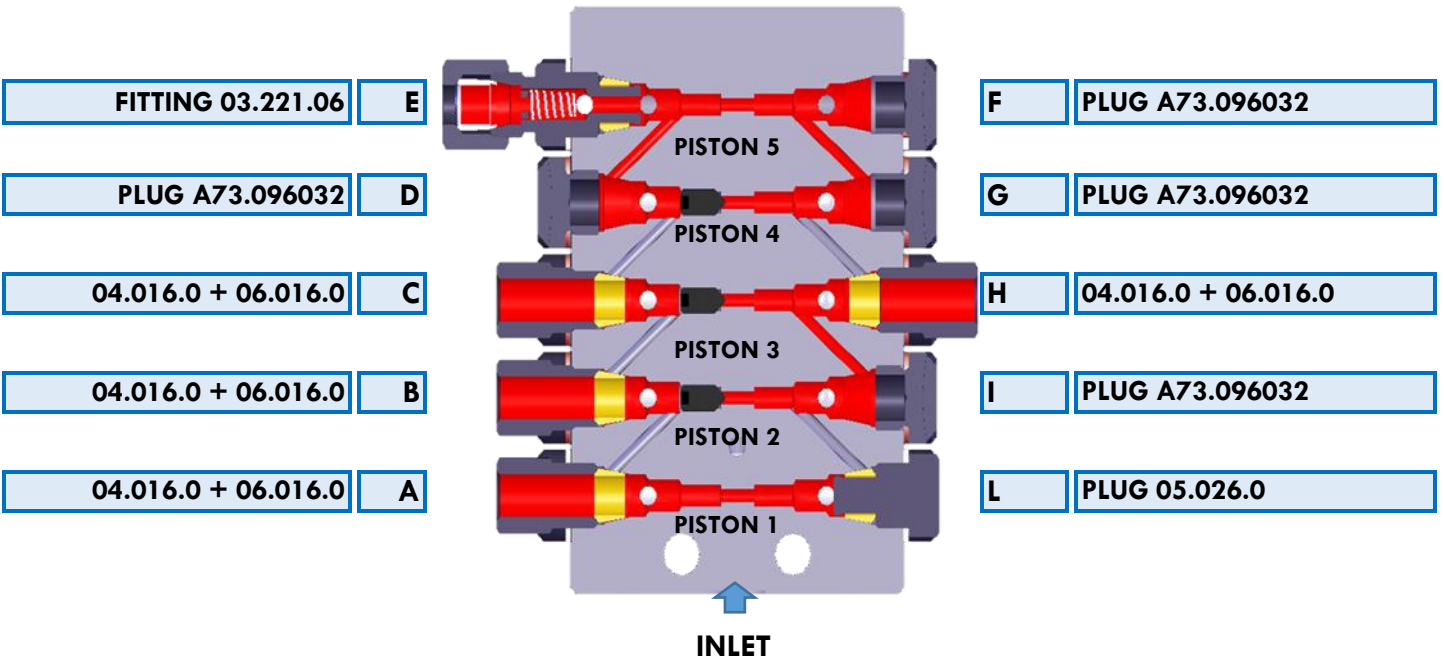

Piston 1 discharge the double quantity of lubricant to the A port

Piston 2 discharge one quantity of lubricant to the B port and the other to H port

Piston 3 discharge one quantity of lubricant to the C port and the other to H port

Piston 4 discharge the double quantity of lubricant to the E port

Piston 5 discharge the double quantity of lubricant to the E port

## 06. HOW TO ORDER

### MONOBLOCK PROGRESSIVE DIVIDER

NAME	OUTLETS	ART. N.	NAME	OUTLETS	ART. N.
DPL-03	6	4.1N.03	DPL-07	14	4.1N.07
DPL-04	8	4.1N.04	DPL-08	16	4.1N.08
DPL-05	10	4.1N.05	DPL-09	18	4.1N.09
DPL-06	12	4.1N.06	DPL-10	20	4.1N.10

### MONOBLOCK PROGRESSIVE DIVIDER WITH VISUAL PIN

NAME	OUTLETS	ART. N.	NAME	OUTLETS	ART. N.
DPL-03V	6	4.2V.03	DPL-07V	14	4.2V.07
DPL-04V	8	4.2V.04	DPL-08V	16	4.2V.08
DPL-05V	10	4.2V.05	DPL-09V	18	4.2V.09
DPL-06V	12	4.2V.06	DPL-10V	20	4.2V.10

### MONOBLOCK PROGRESSIVE DIVIDER WITH INDUCTIVE SENSOR M8X1

NAME	OUTLETS	ART. N.	NAME	OUTLETS	ART. N.
DPL-03I8	6	4.3I.8.03	DPL-07I8	14	4.3I.8.07
DPL-04I8	8	4.3I.8.04	DPL-08I8	16	4.3I.8.08
DPL-05I8	10	4.3I.8.05	DPL-09I8	18	4.3I.8.09
DPL-06I8	12	4.3I.8.06	DPL-10I8	20	4.3I.8.10

### MONOBLOCK PROGRESSIVE DIVIDER WITH INDUCTIVE SENSOR M12X1

NAME	OUTLETS	ART. N.	NAME	OUTLETS	ART. N.
DPL-03I12	6	4.3I.12.03	DPL-07I12	14	4.3I.12.07
DPL-04I12	8	4.3I.12.04	DPL-08I12	16	4.3I.12.08
DPL-05I12	10	4.3I.12.05	DPL-09I12	18	4.3I.12.09
DPL-06I12	12	4.3I.12.06	DPL-10I12	20	4.3I.12.10

### RALL DIMENSIONS

OUTLETS	A [MM]	OUTLETS	A [MM]
6	60	14	120
8	75	16	135
10	90	18	150
12	105	20	165



## 07. OVE

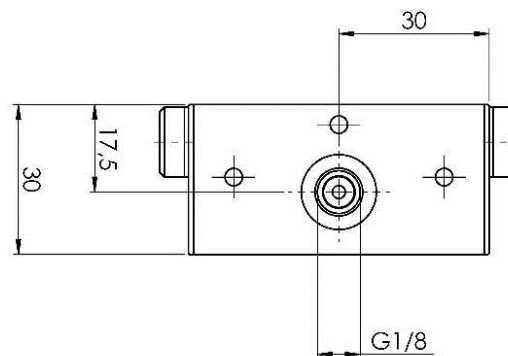
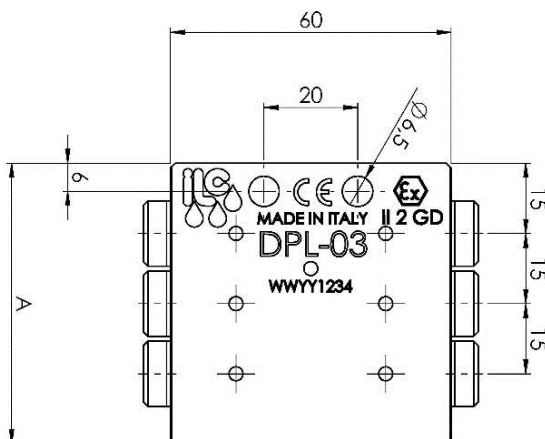
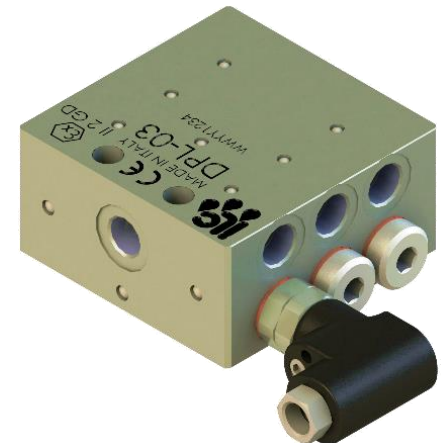



## 08. VISUAL PIN

The visual pin provides monitoring lubrication flow through the system (a stem cycles in and out when lubricant is flowing).

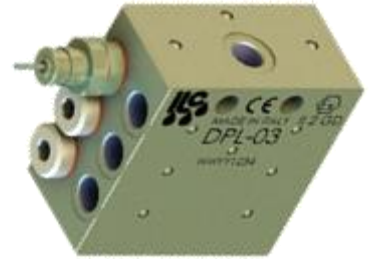

## 09. INDUCTIVE SENSOR CONTROL

A proximity switch is housed in a composit block. It opens and close the contact when the piston moves into its operational seat.

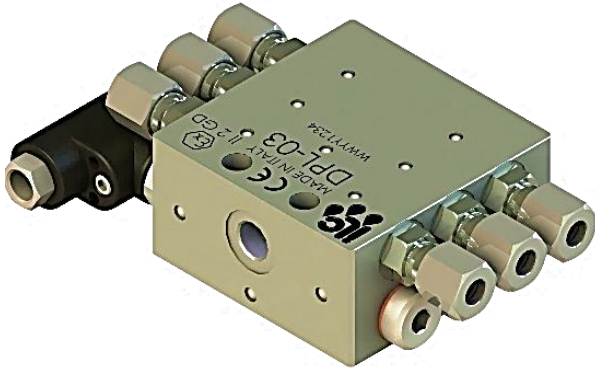

### ELECTRICAL FEATURES

VOLTAGE	6-30 V DC
CONTACT	PNP NO
OUTLET CURRENT	MAX 200 mA
CURRENT	< 12 mA
OPERATING TEMPERATURE	FROM - 25 °C TO 70 °C
PROTECTION	IP 67
SENSOR HOUSING	STAINLESS STEEL
SENSOR BLOCK	PET-G
CONNECTION	M8x1 OR M12x1

### CONNECTION CABLE

ART. N. M8x1 STRAIGHT	LENGHT	ART. N. M12x1 ELBOW	ART. N. M12x1 STRAIGHT
A91.111227	5 M	A91.111316	A91.111349
A91.111348	10 M	A91.111317	A91.111296
A91.111393	15 M	A91.111318	A91.111350
ART. N. SENSOR KIT			
M8x1	<b>49.053.1</b>	M12x1	<b>49.053.2</b>

### ELECTRICAL CONNECTIONS

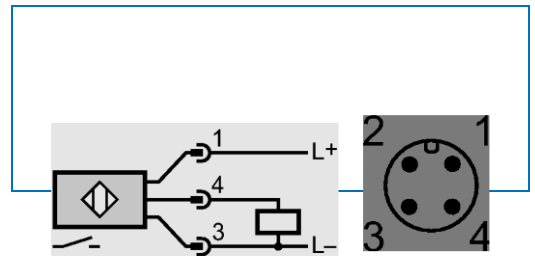

## 10. INDUCTIVE SENSOR CONTROL (ATEX)

Protection II 1G Ex ia IIC T6 Ga II 1D Ex ia IIC T 90°C Da

Protection II 3G Ex nA IIC T6 Gc X II 3D Ex tc T85°C

### Group II, category 1D-1G/2G

ELECTRICAL MODEL	CERTIFIED INTRINSICALLY SAFE CIRCUITS
NOMINAL VOLTAGE [V]	8,2 DC; (1 KΩ)
VOLTAGE	V 7,5...30 DC; USE OUT OF POTENTIALLY EXPLOSIVE AREAS
CURRENT [mA]	< 1 BLOCKER; (> 2,1 mA CONDUCTOR)
CONTACT	NC
CURRENT CAPACITY [mA]	< 30; USE OUT OF POTENTIALLY EXPLOSIVE AREAS
TEMPERATURE [°C]	-20...70
PROTECTION	IP 67
INDUCTIVE SENSOR ART. N.	49.053.2.ATX.1GD

### Group II, category 3D-3G

ELECTRICAL MODEL	DC PNP
TENSION	10-36 V DC
OUTLET CURRENT	MAX 200 mA
CURRENT	< 20 mA
PROTECTION	IP 67
SENSOR HOUSING	STAINLESS STEEL
SENSOR BLOCK	PET-G
CONTACT	NO
INDUCTIVE SENSOR ART. N.	49.053.2.ATX

### ELECTRICAL WIRING

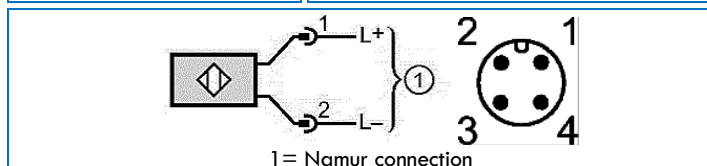

CABLE CONNECTOR 2 M

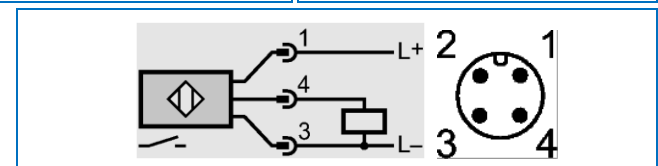

CABLE CONNECTOR 2 M

## 11. SHUT OFF VALVE EV-2

SHUT OFF valves EV-2 are made of a special NC 2-ways solenoid valve and of a modular base that can be directly assembled on the DPL inlet. This can be used when is needed to have a sectioned system

### TECHNICAL FEATURES

Pressure	Max 300 Bar
Lubricant	Oil (min 32 cSt) - Grease max NLGI-1
Temperature	From -20°C to 80°C
Tension	24V DC, 115 - 230 V AC 50/60 Hz.
Power	35 Watt (DC) 8 VA (AC)
Protection	IP54
Inlet	1/4 BSP

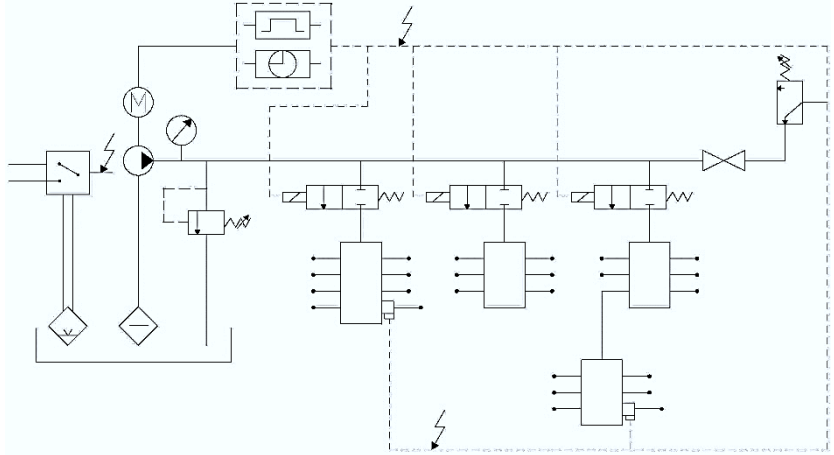
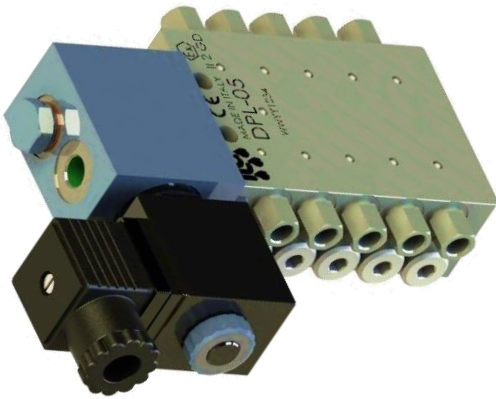

ART. N.	TENSION
14.509.7	24V DC
14.509.7.115	115V AC
14.509.7.230	230V AC

## 12. PRESSURE INDICATORS

These devices are normally used to control the pressure in man and secondary lines. When the pressure becomes excessive the stick moves out and remains in this position until the release lever is actuated by hand. We suggest to do this only after having discovered the reason and the location of the fault.

ART. N.	PRESSURE
09.710.2	50 Bar
09.710.3	75 Bar
09.710.4	100 Bar
09.710.5	150 Bar
09.710.6	200 Bar
09.710.7	250 Bar

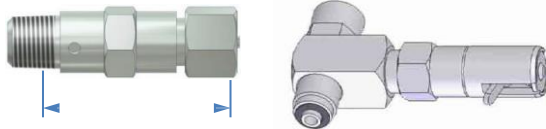

In order to install pressure indicator is needed an elbow adaptor [ART. N. 09.600.5](#)

## 13. INLET ACCESSORIES

### Banjo with grease nipple

ARTICLE NUMBER [03.355.5](#)



### 150 μ strainer

THREAD 1/4 BSP

ARTICLE NUMBER [07.261.0](#)

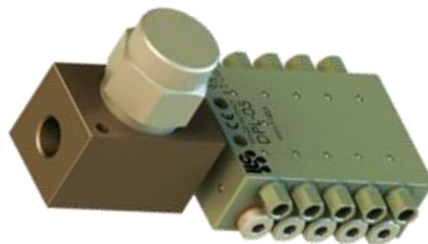

### 70 μ strainer

THREAD 1/4 BSP

ARTICLE NUMBER [07.270.5](#)

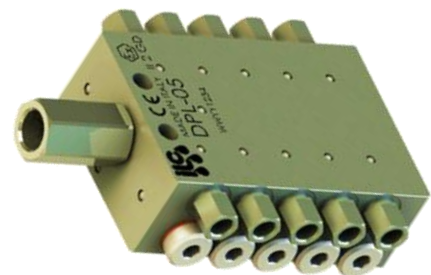



## 14. INLET FITTINGS

Any kind of fitting can be installed on the inlet thread 1/8 BSP

ART. N.		Ø HOSE	FIGURE	PRESSURE	THREAD	DIN 2353	
TW.100504		6 mm	diritto	315 Bar	1/8 BSP		
TW.100525		8 mm	diritto	315 Bar	1/8 BSP		
TW.100528		10 mm	diritto	315 Bar	1/8 BSP		
ART. N.		Ø HOSE	FIGURE	PRESSURE	THREAD		DIN 2353
TW.102004		6 mm	90°	315 Bar	1/8 BSP		
TW.102025		8 mm	90°	315 Bar	1/8 BSP		
TW.102028		10 mm	90°	315 Bar	1/8 BSP		

ART. N.		Ø HOSE	FIGURE	PRESSURE	THREAD	PUSH-IN
03.256.0		6 mm	diritto	250 Bar	1/8 BSP	
ART. N.		Ø HOSE	FIGURE	PRESSURE	THREAD	PUSH-IN
03.256.6		6 mm	90°	250 Bar	1/8 BSP	

## 15. OUTLET FITTINGS

On outlet threads M10x1 can be installed only ILC fittings with sealing cone.

ART. N.		Ø HOSE	FIGURE	PRESSURE	THREAD
04.016.0		6 mm	diritto	250 Bar	M10x1
06.016.0					

ART. N.		Ø HOSE	FIGURE	PRESSURE	THREAD	DIN 2353
03.222.1.04		4 mm	diritto	250 Bar	M10x1	
03.222.1.06		6 mm	diritto	250 Bar	M10x1	
ART. N.		Ø HOSE	FIGURE	PRESSURE	THREAD	CHECK VALVE
14.052.0		6 mm	diritto	250 Bar	M10x1	

ART. N.		Ø HOSE	FIGURE	PRESSURE	THREAD	PUSH-IN
03.255.3.N		4 mm	diritto	250 Bar	M10x1	
03.256.3.N		6 mm	diritto	250 Bar	M10x1	
03.255.8.N		4 mm	90°	250 Bar	M10x1	
03.256.7.N		6 mm	90°	250 Bar	M10x1	
ART. N.		Ø HOSE	FIGURE	PRESSURE	THREAD	CHECK VALVE
03.256.3.NCV		6 mm	diritto	250 Bar	M10x1	

ART. N.		Ø HOSE	FIGURE	PRESSURE	THREAD	In order to use standard fittings it is needed to install also these adaptors 03.222.2 or 03.222.2.CV
03.222.2		---	diritto	350 Bar	M10x1 M/F	
03.222.2.CV			diritto	350 Bar	M10x1 M/F	

PLUG TO CONVEY LUBRICANT TO THE NEXT OUTLET		THREAD	PLUG TO USE OPPOSITE SIDE OF THE SAME PISTON	
	ART. N. 05.026.1	M10x1		ART. N. 05.026.0