



# IMPIANTI LUBRIFICAZIONE ARIA-OLIO

per mandrino  
elettromandrino, viti senza fine  
e ingranaggi

## AIR-OIL LUBRICATION SYSTEMS

for spindle  
motor spindle, ball screws  
and gears



**PRINCIPIO DEGLI IMPIANTI DI LUBRIFICAZIONE  
ARIA-OLIO**

**AIR-OIL LUBRICATION SYSTEMS  
PRINCIPLE**

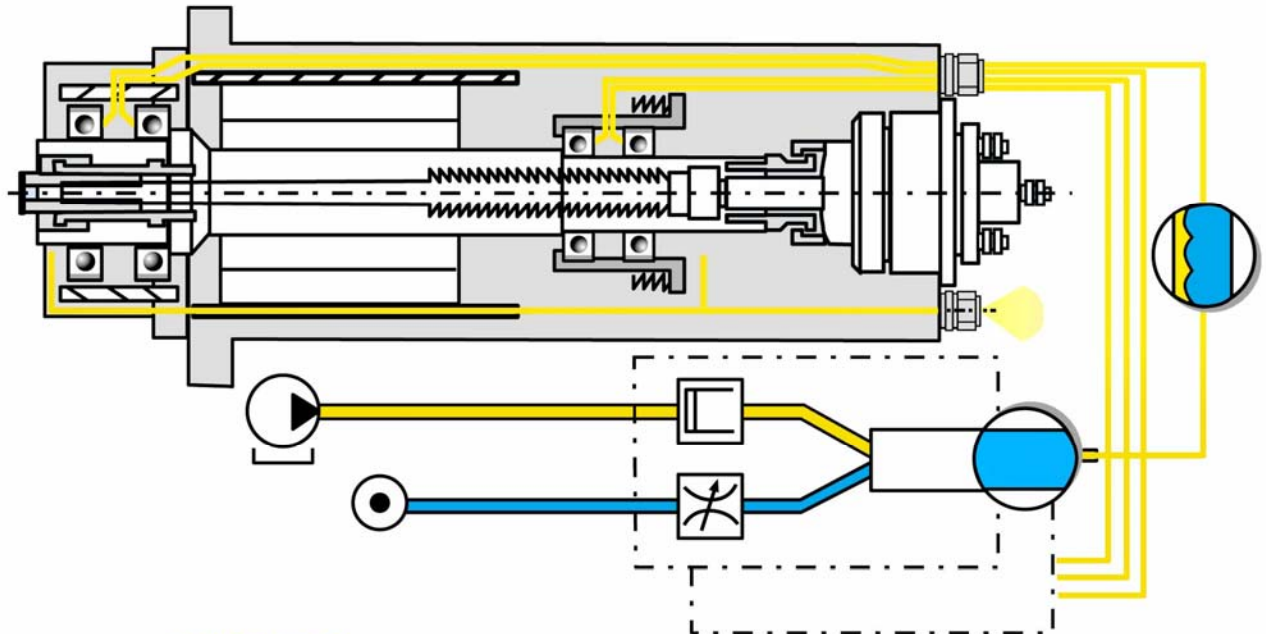

esempio per spindle/example on a spindle

Gli impianti di lubrificazione aria/olio basano il loro principio di funzionamento sulla scomposizione di una goccia d'olio inviata all'interno di una tubazione flessibile di piccolo diametro, dove forma una pellicola d'olio aderente alla parete interna della tubazione stessa. Mediante il flusso d'aria, l'olio è progressivamente inviato verso il punto da lubrificare. Dimensionando opportunamente la lunghezza della tubazione (minimo 1 m) ed il dosaggio dell'olio, si ottiene un invio continuo di microgocce di lubrificante proiettate sul punto da lubrificare che, una volta raggiunto, trattiene l'olio lasciando fuoriuscire liberamente il flusso d'aria verso l'esterno senza creare alcun problema d'inquinamento per l'ambiente. L'effetto refrigerante del flusso d'aria, oltre a mantenere minima la temperatura del cuscinetto, genera una leggera sovrappressione che impedisce la penetrazione di eventuali impurità dall'esterno.

*Air/oil lubrication is based on the principle that a drop of liquid is split by airflow, dispersed in streaks and transported in the direction of the airflow.*

*The drops are transported along the inner wall of a narrow tube in the direction of the lubrication point. With an appropriate length of tube (minimum length 1 m) and a sufficient sequence of oil-delivery cycles, a continuous flow of lubricant arrives at the outlet where it is compressed in the nozzle and fed to the friction point in relatively "large" droplets with the help of air. The oil remains at the friction point and the air, which unlike oil-mist lubrication is nearly free of oil, can escape unimpeded into the open. The air protects bearings from outside contamination and has a fresh effect on the bearings.*



PER MANDRINO  
ELETTROMANDRINO, VITI SENZA FINE  
E INGRANAGGI

FOR SPINDLE  
MOTOR SPINDLE, BALL SCREWS  
AND GEARS

## LE NOSTRE SOLUZIONI: IL MIXER-3

## OUR SOLUTIONS: MIXER-3

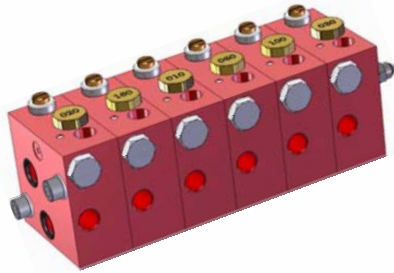

I Mixer-3 incorporano una valvola volumetrica di dosaggio disponibile in diverse portate. La pressione dell'aria in mandata è regolabile mediante una vite con ghiera di bloccaggio posta nella parte superiore del blocchetto. Ogni uscita avrà la sua portata e gli elementi possono essere assemblati fra loro o essere utilizzati singolarmente. Per alimentarli è sufficiente collegare agli appositi ingressi la tubazione principale dell'olio e quella dell'aria.

*Mixers-3 embody a volumetric valve, available with different discharges. Air pressure is adjustable by mean of a screw with a clamping ferrule site up the mixer. Every outlet has her own discharge and elements can be assembled or be individually used. To feed the Mixer-3 is enough connect to the appropriate inlets air main line and oil main line.*

La pompa (elettrica o pneumatica) aziona la valvola interna al Mixer-3 permettendo l'erogazione della quantità prestabilita di olio verso la camera di miscelazione. Il flusso d'aria preleva il lubrificante e lo trasporta nella sede di mandata ad ogni azionamento della pompa. L'aria-olio raggiunge il punto di lubrificazione attraverso la tubazione, scomposto in particelle.

*Pump (electric or pneumatic) activates the Mixer-3 internal valve allowing the discharge of the preset oil quantity towards the mixing chamber. Airflow takes lubricant to the delivery area when the pump is working. Particles air-oil reaches lubrication points via tubes, conveyed by the air.*

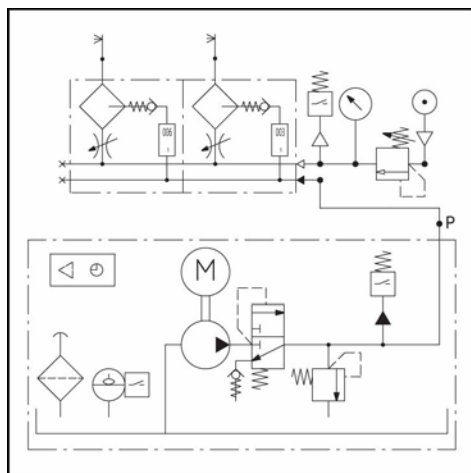

schema idraulico con elettropompa  
*hydraulic layout with electric pump*

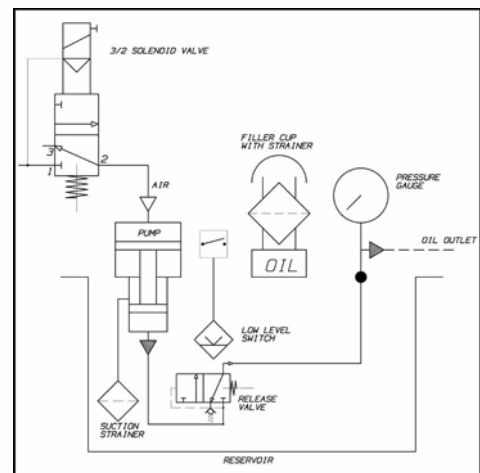

schema idraulico con pompa pneumatica  
*hydraulic layout with pneumatic pump*



**PER MANDRINO  
ELETTROMANDRINO, VITI SENZA FINE  
E INGRANAGGI**

**FOR SPINDLE  
MOTOR SPINDLE, BALL SCREWS  
AND GEARS**

**LE NOSTRE SOLUZIONI:  
LA MICROPOMPA PNEUMATICA**

**OUR SOLUTIONS:  
PNEUMATIC MICROPUMP**



Le micropompe pneumatiche vengono eccitate al termine del tempo di pausa impostato nel MINI-PLC interno o nel controllo della macchina. Ad ogni azionamento, una piccolissima quantità di lubrificante viene aspirata dal serbatoio ed inviata alla camera di miscelazione situata nella sottobase della micropompa. Una volta raggiunta la camera di miscelazione, l'olio viene scomposto in particelle e trasportato nelle tubazioni di collegamento ai punti mediante un flusso d'aria costante. Il passaggio del lubrificante dalla micropompa alla camera di dosaggio è controllato mediante il sensore induttivo posto nella parte terminale della micropompa.

*Micro pneumatic pumps are switched on at the end of the pause time set with the PLC "Millenium" (or with the machine PLC). They feed a metered quantity of oil from the reservoir to the mixing chambers of the pump bases. In the mixing chamber the oil is divided in particles and conveyed through the lines to the friction points by the continuous flow of compressed air. The oil in the delivery line is monitored from the PLC "Millenium" by mean of inductive sensors.*

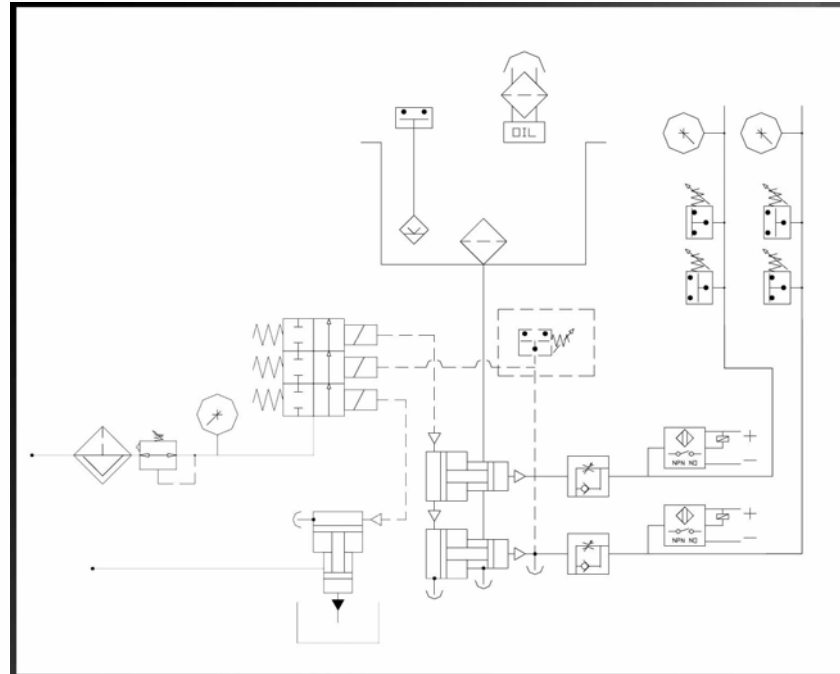

schema idraulico con micropompa pneumatica  
*hydraulic layout with micro pneumatic pump*



## POMPA PNEUMATICA PRA 15

## PRA-15 PNEUMATIC PUMP

LE POMPE A COMANDO PNEUMATICO PRA SONO DESTINATE ALL'ALIMENTAZIONE DI IMPIANTI DI LUBRIFICAZIONE FUNZIONANTI AD OLIO DOVE SONO INSTALLATI MIXER-3. IL GRUPPO POMPA E' APPLICATO NELLA PARTE SUPERIORE DEL SERBATOIO E L'ALIMENTAZIONE DEVE ESSERE EFFETTUATA MEDIANTE UNA ELETTROVALVOLA PNEUMATICA A 3 VIE ( LINEA - CILINDRO - SCARICO ). IL RITORNO ALLA POSIZIONE INIZIALE DEL PISTONE A SEMPLICE EFFETTO È ASSICURATO DA UNA MOLLA. PER UN CORRETTO FUNZIONAMENTO DELL'IMPIANTO L'IMPULSO DI COMANDO NON DEVE ESSERE INFERIORE A 15 SECONDI. ALL'INTERNO DEL GRUPPO POMPA SONO ALLOGGiate LE VALVOLE DI ASPIRAZIONE - MANDATA E DECOMPRESSIONE. SONO INOLTRE DOTATE DI FILTRO DI ASPIRAZIONE, FILTRO DI CARICO E SEGNALEZIONE ELETTRICA DI MINIMO LIVELLO. A RICHIESTA È POSSIBILE DOTARE LE POMPE DI UN MANOMETRO.

THE PNEUMATIC PUMP PRA IS SUPPLIED FOR CENTRALIZED LUBRICATION SYSTEM WITH OIL WHERE MIXER-3 ARE USED. THE PUMP ASSEMBLY IS LOCATED OVER THE RESERVOIR AND THE AIR HAS TO BE SEND VIA A 3-WAYS SOLENOID VALVE (LINE - CYLINDER - RELEASE). THE PISTON COMES BACK BY MEANS OF A SPRING. THE PAUSE TIME HAS NOT TO BE LESS THAN 15 SECONDS FOR A CORRECT USE OF THE PUMP.

THE PUMP IS PROVIDED WITH A SUCTION VALVE, A CHECK VALVE, A RELEASE VALVE, A SUCTION STRAINER, A STRAINER FILLER CUP AND A LOW LEVEL SWITCH. IT IS POSSIBLE TO SUPPLY ON REQUEST A PRESSURE GAUGE.

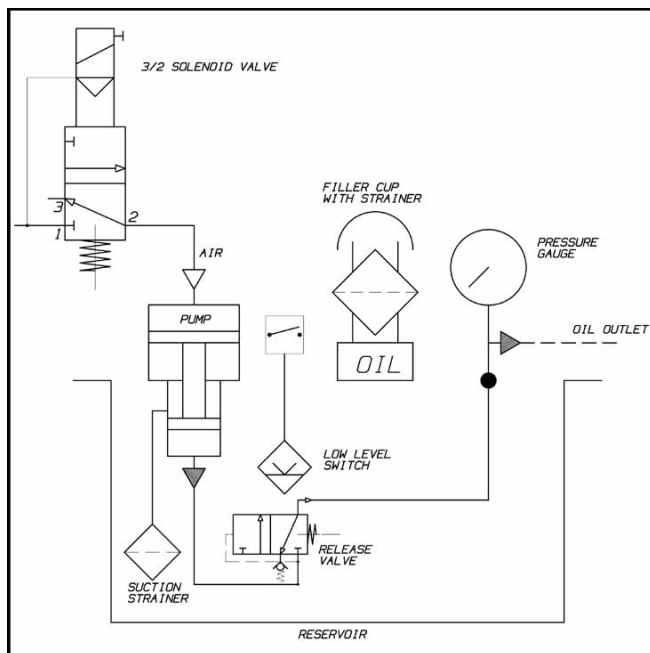

**POMPA PNEUMATICA PRA-15**

**PRA-15 PNEUMATIC PUMP**

CARATTERISTICHE

FEATURES

PORTATA/CICLO	2.7 CC	DISCHARGE/CYCLE	2.7 CC
PRESSIONE ESERCIZIO	56 BAR (795 PSI) MAX	WORKING PRESSURE	56 BAR (795 PSI) MAX
RAPPORTO	8 ÷ 1	RATIO	8 ÷ 1
PRESSIONE ARIA	DA 4 BAR A 7 BAR	AIR OPERATING PRESSURE	FROM 4 BAR TO 7 BAR
	DA 60 PSI A 100 PSI		FROM 60 PSI TO 100 PSI
VALVOLA DI RILASCIO	0.7 BAR (10 PSI)	RELEASE VALVE	0.7 BAR (10 PSI)
NUMERO CICLI/MINUTO	MAX 6	CYCLES NUMBER/MINUTE	MAX 6
SERBATOI IN NYLON	2 L - 3.6 L	PLASTIC RESERVOIR	2 L - 3.6 L
FILTRO DI ASPIRAZIONE	250 MICRON	SUCTION STRAINER	250 MICRON
RACCORDO DI MANDATA	1/8"	DISCHARGE PORT	1/8"
TEMPERATURA ESERCIZIO	DA -10°C A +80°C	TEMPERATURE RANGE	FROM -10°C TO +80°C
LUBRIFICANTI	OLII 25-1000 cSt 40°C	LUBRICANTS	OIL 25-1000 cSt 40°C
MINIMO LIVELLO	1.5 A 250 V AC - 150 V DC	LOW LEVEL SWITCH	1.5 A 250 V AC - 150 V DC
INGRESSO ARIA	1 / 8" G	AIR INLET	1 / 8" G

CODICI DI ORDINAZIONE

CODES FOR ORDER

CODICE CODE	SIGLA TYPE	CAPACITA' SERBATOIO RESERVOIR CAPACITY	FILTRO DI RITORNO RETURN STRAINER
00.224.3	PRA-15/2	2 L	NO
00.224.6	PRA-15/3.6	3.6 L	NO
ACCESSORI A RICHIESTA		COD.	EQUIPMENT ON REQUEST
MANOMETRO RADIALE 1/8" 0-60 BAR		46.300.0	PRESSURE GAUGE 0-60 BAR

DIMENSIONI D'INGOMBRO

OVERALL DIMENSION

POMPA PUMP	A	B	C	D	E	F
PRA-15/2	160	186	198	125	123	148
PRA-15/3.6	155	174	193	173	135	230

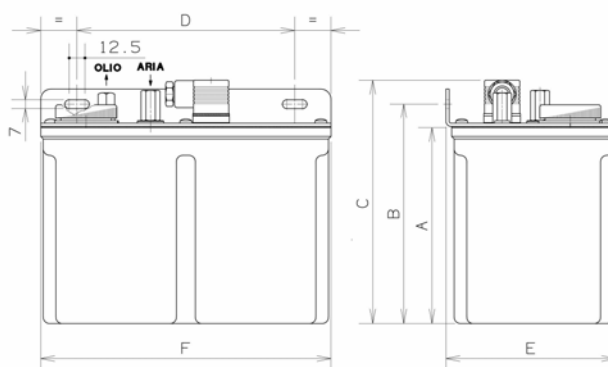

**ELETTROPOMPA MPT-3**

**MPT-3 ELECTRIC PUMP**

LE ELETTROPOMPE MPT SONO DESTINATE ALL'ALIMENTAZIONE DI IMPIANTI DI LUBRIFICAZIONE FUNZIONANTI AD OLIO DOVE SONO INSTALLATI MIXER-3. IL GRUPPO MOTORE POMPA, E' APPLICATO AD UNA SQUADRA IN LAMIERA CHE FUNGE DA COPERCHIO DEL SERBATOIO. ALLA POMPA AD INGRANAGGI È APPLICATO UN GRUPPO VALVOLE CHE PROVVEDE ALLE FUNZIONI DI INNESCO (SPURGO AUTOMATICO DELL'ARIA IN FASE DI PARTENZA) – DECOMPRESSIONE (RILASCIO AUTOMATICO DELLA PRESSIONE NEL CIRCUITO AL TERMINE DEL CICLO DI LAVORO ) E SICUREZZA ( SCARICO AUTOMATICO DEL LUBRIFICANTE ALL'INTERNO DEL SERBATOIO AL RAGGIUNGIMENTO DELLA MASSIMA PRESSIONE DI ESERCIZIO) SONO INOLTRE DOTATE DI FILTRO DI ASPIRAZIONE – FILTRO DI CARICO - SEGNALAZIONE ELETTRICA DI MINIMO LIVELLO E MANOMETRO.

*THE GEAR ELECTRIC PUMPS MPT ARE SUPPLIED FOR CENTRALIZED LUBRICATION SYSTEM WITH OIL WHERE MIXER-3 ARE USED. THE MOTOR PUMP ASSEMBLY IS LOCATED ON A STEEL-SHEET ANGLE PLATE PROVIDED WITH HOLES FOR WALL MOUNTING. THIS IS ALSO THE COVER FOR THE RESERVOIR.*

*THE GEAR PUMP IS PROVIDED WITH A SET OF VALVES WHICH CARRIES OUT PRIMING (THE VENT VALVE PURGE AIR WHEN THE MOTOR STARTS), RELASING (THE RELEASE VALVE OPEN WHEN THE PUMP STOPS TO RUN TO RELEASE THE PRESSURE) AND RELIEFING (THE RELIEF VALVE OPEN TO AVOID OVERPRESSURE IN THE SYSTEM). THEY ARE PROVIDED WITH SUCTION STRAINER, LOW LEVEL SWITCH, PRESSURE GAUGE AND STRAINER FILLER CUP.*

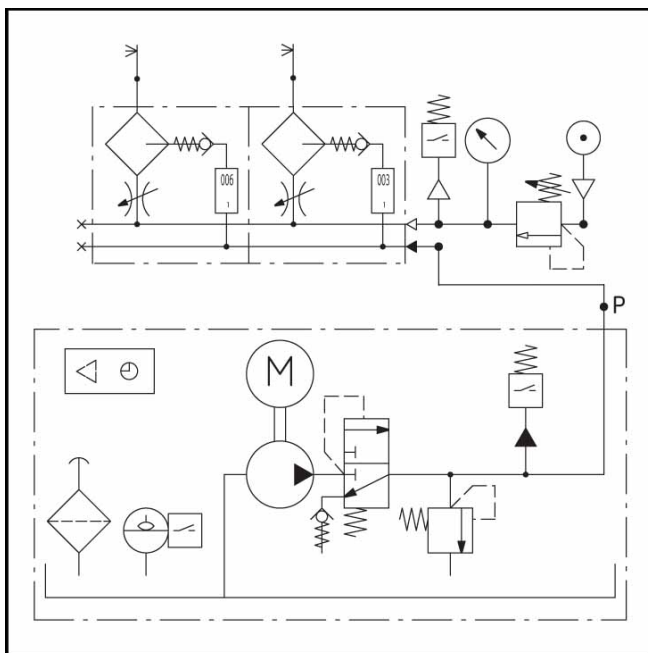

**ELETTROPOMPA MPT-3**

**MPT-3 ELECTRIC PUMP**

**CARATTERISTICHE**

**FEATURES**

PORTATA/MINUTO	500 CC	DISCHARGE/MINUTE	500 CC
PRESSIONE DI ESERCIZIO	15-50 BAR (212-708 PSI) REGOLABILE	WORKING PRESSURE	15-50 BAR (212-708 PSI) ADJUSTABLE
VALVOLA DI RILASCIO	0.7 BAR	RELEASE VALVE	0.7 BAR
SERBATOIO	3 L	RESERVOIR	3 L
FILTRO DI ASPIRAZIONE	250 MICRON	SUCTION STRAINER	250 MICRON
MANOMETRO	0 - 60 BAR / 0 - 870 PSI	PRESSURE GAUGE	0 - 60 BAR / 0 - 870 PSI
RACCORDO DI MANDATA	M12X1 TUBO 6mm	DISCHARGE PORT	M12X1 TUBE 6mm
TEMPERATURA DI	DA -20°C A +80°C	TEMPERATURE RANGE	FROM -20°C TO +80°C
LUBRIFICANTI	OLII 25 - 1000 cSt 40°C	LUBRICANTS	OIL 25 - 1000 cSt 40°C
MINIMO LIVELLO	1.5 A 250V AC 200V DC 50 W	LOW LEVEL SWITCH	1.5 A 250 V AC 200 V DC 50 W

**CODICI DI ORDINAZIONE**

**CODES FOR ORDER**

CODICE <i>CODE</i>	SIGLA <i>TYPE</i>	CAPACITA' SERBATOIO <i>RESERVOIR CAPACITY</i>	PRESSIONE <i>PRESSURE</i>
60.822.2	MPT-3-NY-500-50	3 L NYLON/PLASTIC	15 - 50 BAR

A RICHIESTA E' POSSIBILE FORNIRE MOTORI MONOFASI 115 V - 230 V AC 50/60HZ O CON TENSIONI SPECIALI. IN QUESTO CASO AGGIUNGERE AL CODICE DI ORDINAZIONE LA TENSIONE.

ON REQUEST CAN BE SUPPLIED SPECIAL MOTOR VOLTAGES OR SINGLE PHASE 115 V - 230 V AC 50/60HZ. IN THIS CASE ADD THE VOLTAGE TO THE ORDER CODE.

**DIMENSIONI D'INGOMBRO**

**OVERALL DIMENSION**

POMPA <i>PUMP</i>	A	B	C	D	E	F	PESO <i>WEIGHT</i>
MPT-3-NY	155	181	335	167	165	230	5.3 KG

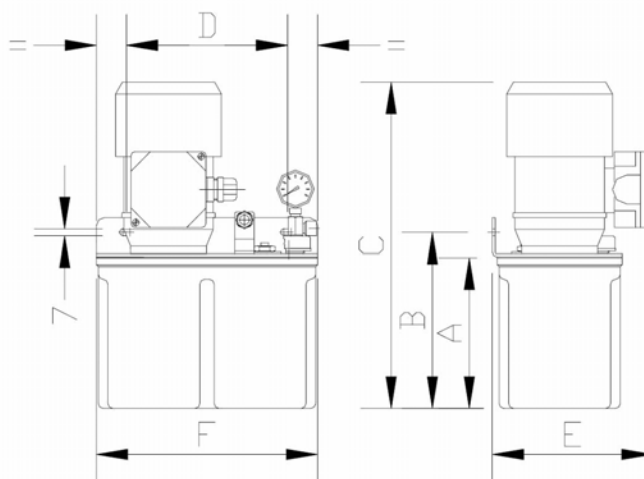



**ELETTROPOMPA CME**

**CME ELECTRIC PUMP**

LE ELETTROPOMPE CME SONO DESTINATE ALL'ALIMENTAZIONE DI IMPIANTI DI LUBRIFICAZIONE ARIA-OLIO PER ALIMENTARE LE VALVOLVE MISCELATRICI MIXER-3. IL GRUPPO E' COMPOSTO DA UNA POMPA AD INGRANAGGI CON PORTATA DA 100 A 200 CC/MIN, UN MOTORE ELETTRICO MONOFASE 115 V AC O 230 V AC (A RICHIESTA 24 V DC), UN SEGNALETTORIO ELETTRICO DI MINIMO LIVELLO, UNA SCHEDA ELETTRONICA (A RICHIESTA) ED UN PRESSOSTATO (A RICHIESTA) ALLOGGIATI ALL'INTERNO DI UNA SCATOLA DI PROTEZIONE. IL SERBATOIO TRASPARENTE ANTIURTO HA UNA CAPACITA' DI 3 L. ALLA POMPA AD INGRANAGGI E' COLLEGATO UN GRUPPO VALVOLVE CHE PROVVEDE ALLE FUNZIONI DI DECOMPRESSIONE - SPURGO ARIA E BY/PASS. LA SCHEDA ELETTRONICA COMANDA E CONTROLLA IL SISTEMA IN DIVERSE MODALITÀ. ESSA HA LA POSSIBILITA' DI REGOLARE IL TEMPO DI RIPOSO E TEMPO DI LAVORO MEDIANTE I DIP-SWITCHES, DI CONTROLLARE IL SISTEMA PER MEZZO DI UN PRESSOSTATO (INTERNO OD ESTERNO) E DI INSERIRE O DISINSERIRE LA FUNZIONE DI PRELUBRIFICAZIONE EXTRA-CICLO. INOLTRE I VARI SEGNALI DI ALLARME POSSONO ESSERE INVIATI A DISTANZA.

*CME ELECTRIC PUMPS HAVE BEEN DEVELOPED FOR AIR-OIL SYSTEM WITH MIXER-3 VALVES. CME HAS THE GEAR PUMP WITH A DISCHARGE FROM 100 TO 200 CC/MIN, THE SINGLE PHASE MOTOR 115 V OR 230 V AC (ON REQUEST 24 V DC), THE LOW LEVEL SWITCH, THE INTEGRATED ELECTRONIC CARD (ON REQUEST) AND THE PRESSURE SWITCH (ON REQUEST) INSIDE IN THE HOUSING. THE IMPACT RESISTANT TRANSPARENT RESERVOIR HAS A CAPACITY OF 3 LITERS. THE GEAR PUMP IS COMPLETE OF VALVES TO RELIEF - PURGE AIR AND BY/PASS. THE INTEGRATED ELECTRONIC CARD CONTROLS AND SUPERVISES THE SYSTEM IN MANY WAYS. IT HAS THE POSSIBILITY TO ADJUST THE PAUSE TIME AND WORKING TIME BY MEANS OF DIP-SWITCHES, TO CONTROL THE SYSTEM BY MEANS OF A PRESSURE SWITCH (INSIDE OR OUTSIDE), TO SELECT IF IS REQUIRED OR NOT THE PRE-LUBRICATION FUNCTION AND TO HAVE THE REMOTE ALARM SIGNAL.*

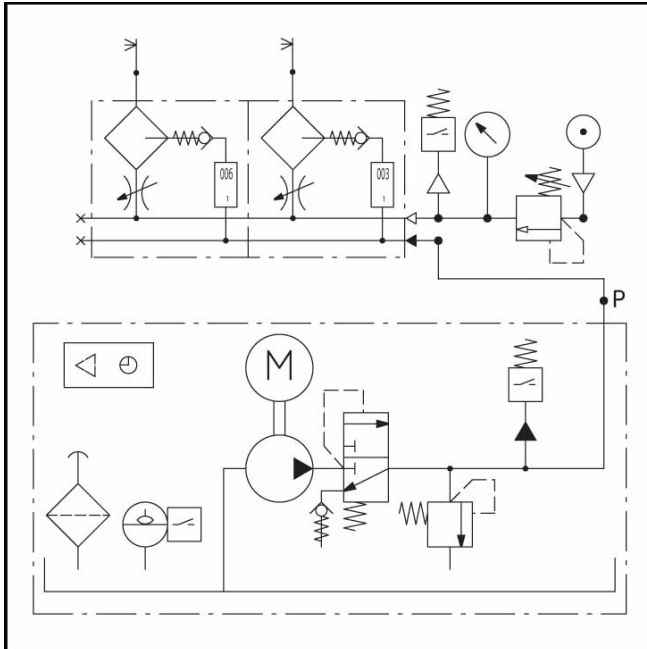

**ELETTROPOMPA CME**

**CME ELECTRIC PUMP**

MOTORE 115 V AC 0 230 V AC	MONOFASE AD INDUZIONE	MOTOR 115 V AC OR 230 V AC	SINGLE-PHASE
POTENZA	110 W	POWER RATING	110 W
ASSORBIMENTO	0.75 A (230 V) 1.5 A (115 V)	CURRENT	0.75 A (230 V) 1.5 A (115 V)
PROTEZIONE	IP 33- CLASSE B	PROTECTION	IP-33 CLASS B
MOTORE 24 V DC	30 W – 1.5 A	MOTOR 24 V DC	30 W – 1.5 A
PORTATA /1'	DA 100 A 200 CC	DISCHARGE/1'	FROM 100 TO 200 CC
PRESSIONE DI ESERCIZIO	24 BAR MAX PER OLIO	WORKING PRESSURE	24 BAR MAX FOR OIL
SERBATOIO	NYLON 3 LITRI	RESERVOIR	NYLON 3 LITERS
LUBRIFICANTI	OLII 25 - 1000 cSt	LUBRICANTS	OIL 25 - 1000 cSt
FILTRO DI ASPIRAZIONE	250 MICRON	SUCTION STRAINER	250 MICRON
MINIMO LIV. ELETTRICO	OLIO 1.5 A - 250 V AC - 150 V DC	LOW LEVEL RATINGS	OIL 1.5 A - 250 V AC - 150 V DC
MANOMETRO	0-60 BAR A RICHIESTA	PRESSURE GAUGE	0-60 BAR ON REQUEST
TEMPO DI PAUSA	DA 2.5 MINUTI A 21 ORE	PAUSE TIME	FROM 2.5 MIN TO 21 HOURS
TEMPO DI LAVORO	DA 5 A 90 SECONDI	WORKING TIME	FROM 5 TO 90 SECONDS
RACCORDO MANDATA	M12X1 TUBO 6 MM	DISCHARGE PORT	M12X1 TUBE 6 MM
PULSANTE	LUBRIF. MANUALE - RESET	PUSH BUTTON	EXTRA CYCLES - RESET
LED VERDE	TENSIONE IN LINEA	GREEN LAMP	ON LINE
LED GIALLO	POMPA IN FUNZIONE	YELLOW LAMP	WORK PUMP
LED ROSSO	ALLARME LIVELLO ALLARME PRESSIONE	RED LAMP	LOW-LEVEL ALARM PRESSURE ALARM
TEMPERATURA	DA -10 °C A +60 °C	OPERATING TEMPERATURE	FROM -10 °C TO +60 °C

COD.	SIGLA/TYPE	SERBATOIO/RESERVOIR	
00.870.6 00.870.7	CME CC+PFL 115 V AC CME CC+PFL 230 V AC	3 L	CON TIMER E PRESSOSTATO <i>WITH TIMER AND PRESSURE SWITCH</i>
00.870.8 00.870.9	CME CE + PULS + PFL 115 V AC CME CE + PULS + PFL 230 V AC	3 L	SENZA TIMER – CON PULSANTE E PRESSOSTATO <i>WITHOUT TIMER – WITH P. BUTTON AND PRESS. SWITCH</i>
ACCESSORI A RICHIESTA		COD.	<i>EQUIPMENT ON REQUEST</i>
MANOMETRO RADIALE 1/8" 0-60 BAR		46.300.0	PRESSURE GAUGE 0-60 BAR

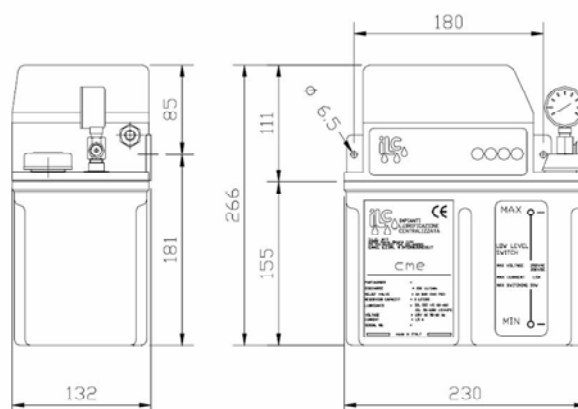

PER MANDRINO  
ELETTROMANDRINO, VITI SENZA FINE  
E INGRANAGGI

FOR SPINDLE  
MOTOR SPINDLE, BALL SCREWS  
AND GEARS

**VALVOLE MISCELATRICI ARIA+OLIO MIXER-3**

**MIXER-3 AIR+OIL MIXING VALVES**



**CARATTERISTICHE**

**FEATURES**

INGRESSO LINEA ARIA	1/8"	AIR INLET	1/8"
INGRESSO LINEA OLIO	1/8"	OIL INLET	1/8"
USCITA ARIA+OLIO	1/8"	AIR+OIL OUTLET	1/8"
PRESSIONE OLIO	MIN 20 BAR MAX 35 BAR	OIL PRESSURE	MIN 20 BAR MAX 35 BAR
PRESSIONE ARIA	MIN 0,5 BAR MAX 8 BAR	AIR PRESSURE	MIN 0,5 BAR MAX 8 BAR
VITI DI FISSAGGIO	VITE M5x60	CLAMPING SCREWS	5x60M SCREW
LUBRIFICANTI	OLIO MAX 220 cSt 40°C	LUBRICANTS	OIL MAX 220 cSt 40°C
TEMPERATURA	DA 5°C A 80°C	TEMPERATURE	FROM 5°C TO 80°C
POSIZ. DI MONTAGGIO	USCITA VERSO L'ALTO	MOUNTING POSIT.	UPSIDE OUTLET

**CODICI PER ORDINAZIONI**

**ORDER CODES**

ELEMENTI SINGOLI - SINGLE PARTS		CARTUCCIA - CARTRIDGE	
CODICE CODE	PORTATA DISCHARGE	CODICE CODE	PORTATA DISCHARGE
02.909.0.010	10 MM <sup>3</sup>	02.909.1.010	10 MM <sup>3</sup>
02.909.0.020	20 MM <sup>3</sup>	02.909.1.020	20 MM <sup>3</sup>
02.909.0.030	30 MM <sup>3</sup>	02.909.1.030	30 MM <sup>3</sup>
02.909.0.060	60 MM <sup>3</sup>	02.909.1.060	60 MM <sup>3</sup>
02.909.0.100	100 MM <sup>3</sup>	02.909.1.100	100 MM <sup>3</sup>
02.909.0.160	160 MM <sup>3</sup>	02.909.1.160	160 MM <sup>3</sup>

**DIMENSIONI DI INGOMBRO**

**OVERALL DIMENSIONS**

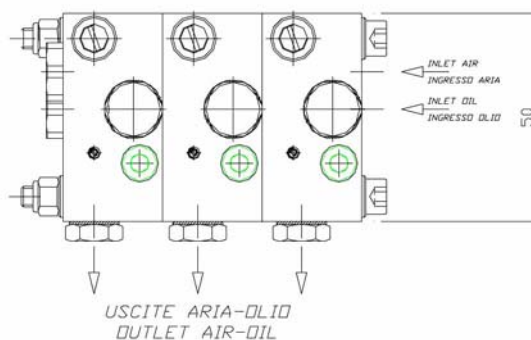
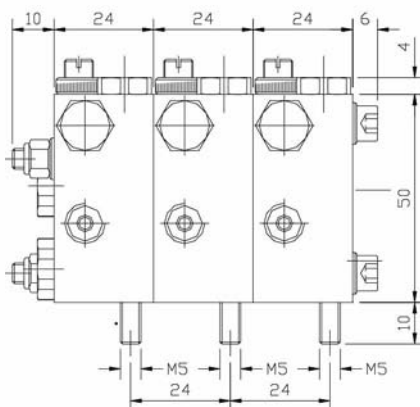

**VALVOLE MISCELATRICI ARIA+OLIO MIXER-3**

**MIXER-3 AIR+OIL MIXING VALVES**

Le valvole miscelatrici aria+olio Mixer-3 possono essere assemblate fino a gruppi di 8 o più. Per gruppi di numero superiore rivolgersi al nostro ufficio tecnico. Ogni uscita dev'essere connessa al punto da lubrificare. Le portate possono essere scelte fra 10 mm<sup>3</sup>, 20 mm<sup>3</sup>, 30 mm<sup>3</sup>, 60 mm<sup>3</sup>, 100 mm<sup>3</sup> e 160 mm<sup>3</sup>.

*Air+oil mixing valves Mixer-3 can be combined until 8 or more blocks. To have groups of higher valves please be so kind as to contact our technical department. Every outlet port has to be connected to the lube point. Discharges can be chosen between 10 mm<sup>3</sup>, 20 mm<sup>3</sup>, 30 mm<sup>3</sup>, 60 mm<sup>3</sup>, 100 mm<sup>3</sup> and 160 mm<sup>3</sup>.*

codice tiranti / <i>tie rods code</i>	n. di blocchi / <i>number of block</i>
A70.093279	2
A70.093280	3
A70.093281	4
A70.093282	5
A70.093283	6
A70.093284	7
A70.093285	8



Il codice si riferisce ad un **solo** tirante. Ogni blocco necessita di **due** tiranti.  
*Ordering the code you will have just one tie rod. Every block needs two tie rods.*

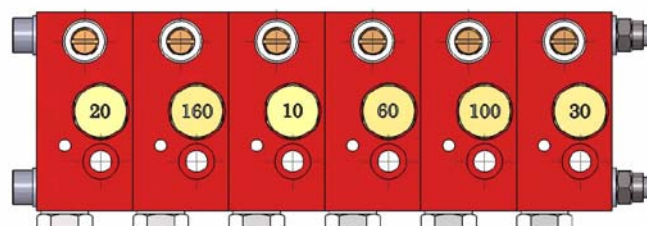

**CODICI PER ORDINAZIONE / ORDER CODES**

Cod.	Uscite / <i>Outlets</i>
<b>MX01</b>	1
<b>MX02</b>	2
<b>MX03</b>	3
<b>MX04</b>	4
<b>MX05</b>	5
<b>MX06</b>	6
<b>MX07</b>	7
<b>MX08</b>	8

Portata / <i>Discharge</i>	Marcatura / <i>Marking</i>
10 mm <sup>3</sup>	<b>10</b>
20 mm <sup>3</sup>	<b>20</b>
30 mm <sup>3</sup>	<b>30</b>
60 mm <sup>3</sup>	<b>60</b>
100 mm <sup>3</sup>	<b>100</b>
160 mm <sup>3</sup>	<b>160</b>

Esempio di ordinazione / *Order example:*

**MX06:20-160-10-60-100-30**

per ordinare un Mixer-3 da 6 uscite, con le rispettive portate  
*to order a Mixer-3 of 6 outlets and indicating discharges*



Indicare le portate delle valvole in caso di ordine, da sinistra a destra, come mostrato nell'esempio.  
*Please indicate valves discharge when ordering, from left to right, as shown in the example below.*



**RACCORDI STANDARD**

**STANDARD FITTINGS**

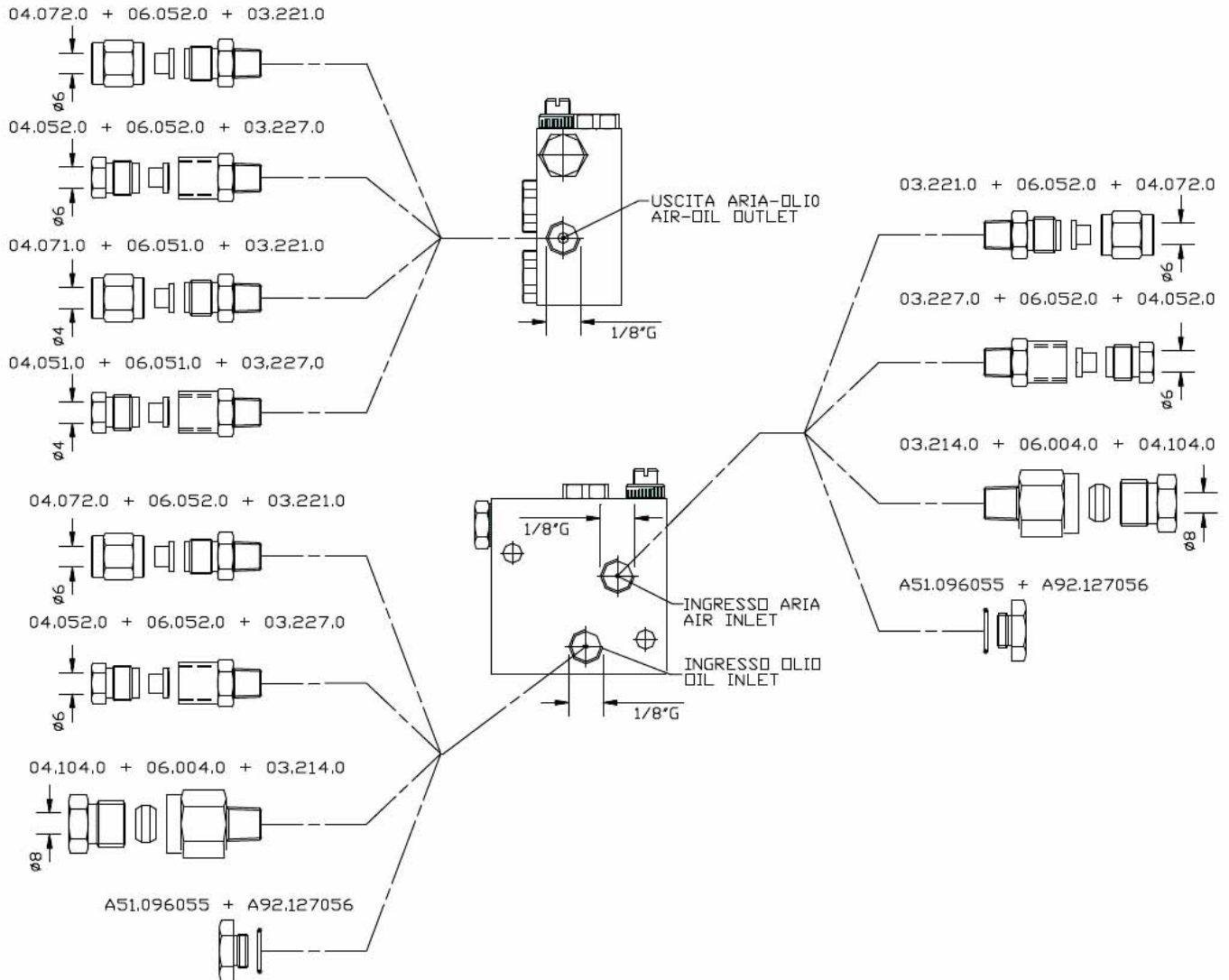

PER MANDRINO  
ELETTRIMANDRINO, VITI SENZA FINE  
E INGRANAGGI

FOR SPINDLE  
MOTOR SPINDLE, BALL SCREWS  
AND GEARS

**RACCORDI RAPIDI**

**PUSH-IN FITTINGS**

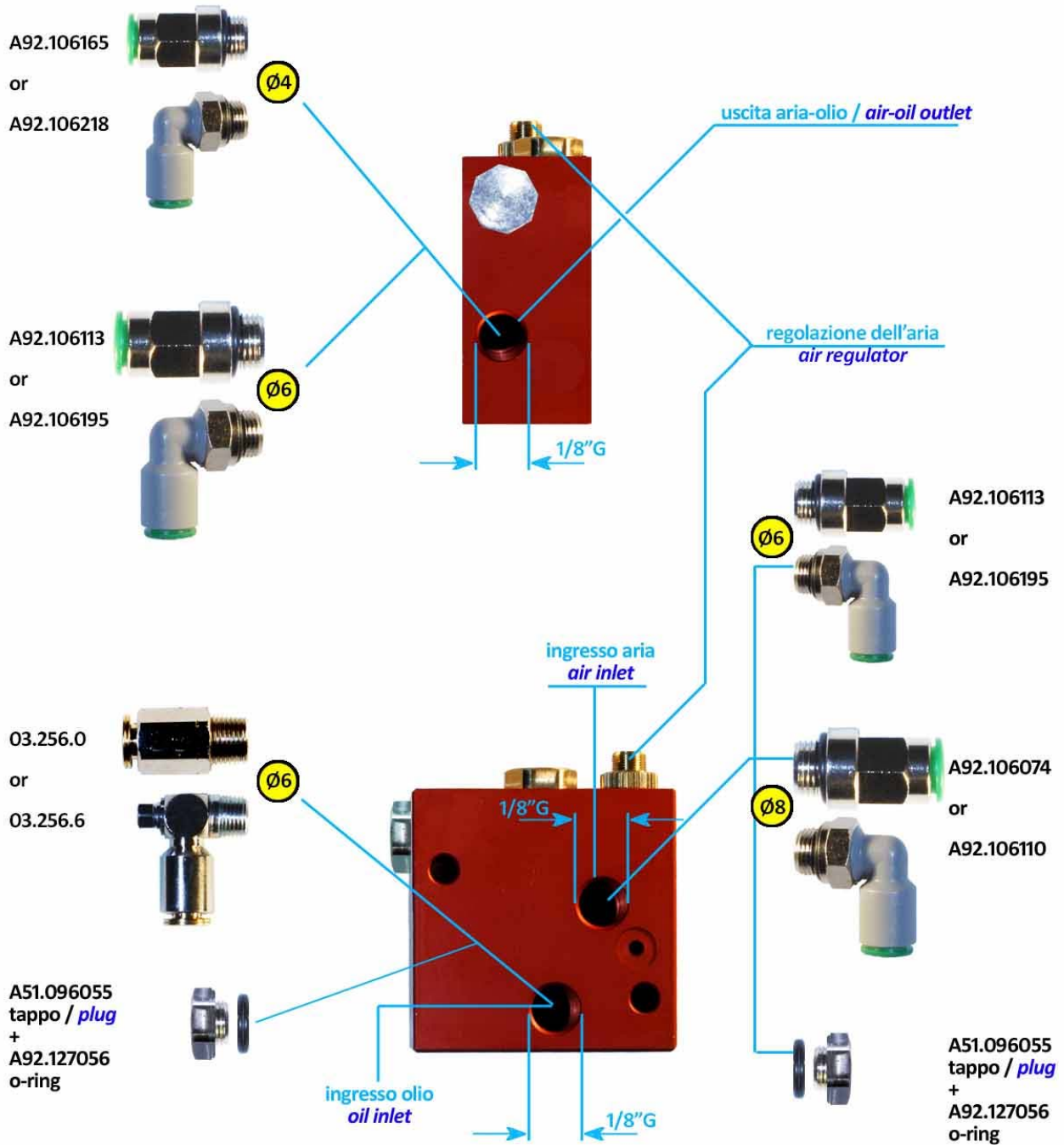

**ESEMPIO DI SCHEMA (CON POMPA PNEUMATICA)**

**LAYOUT EXAMPLE (WITH PNEUMATIC PUMP)**

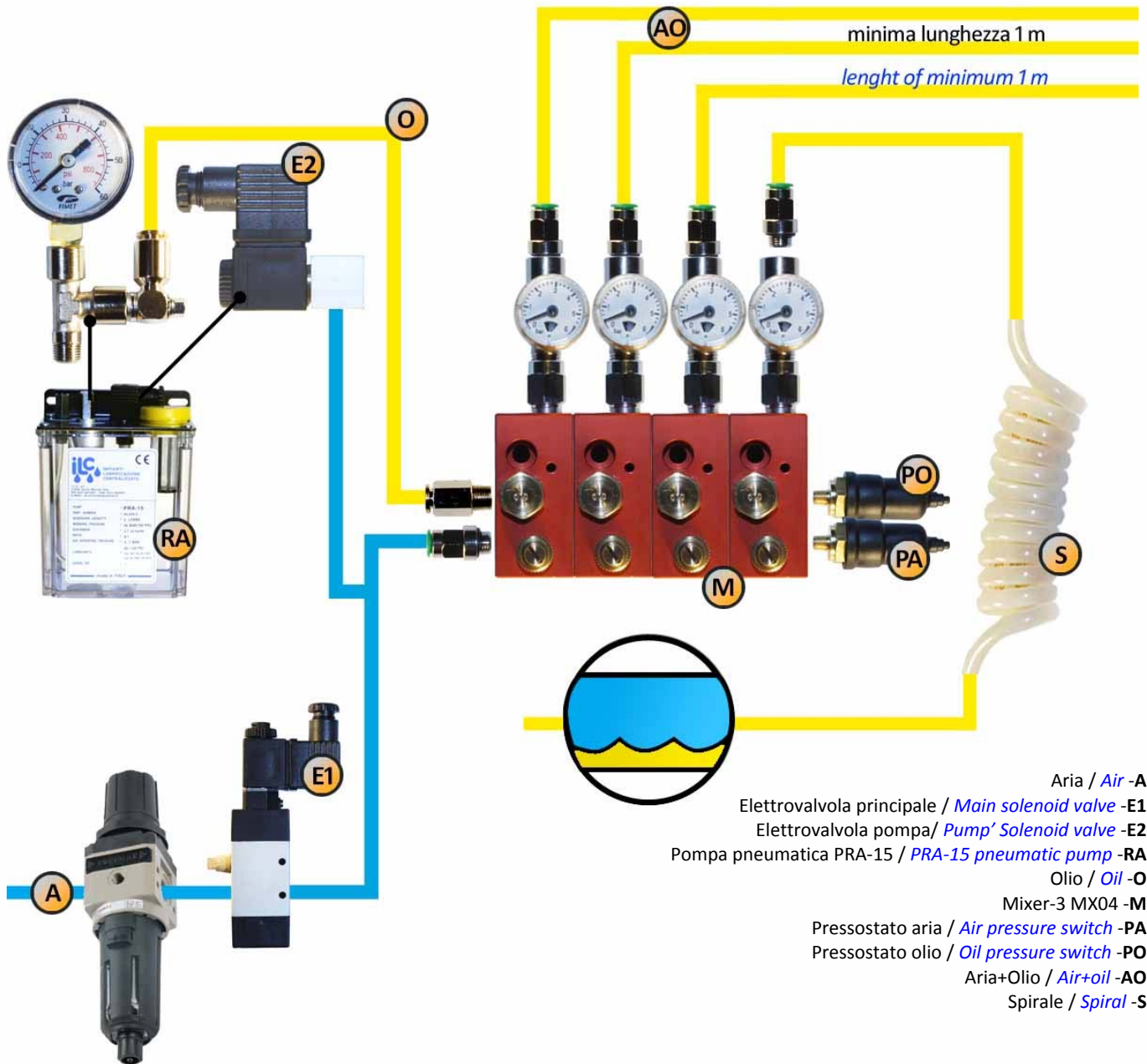

**ESEMPIO DI SCHEMA  
CON POMPA ELETTRICA MONOFASE**

**LAYOUT EXAMPLE  
WITH SINGLE-PHASE ELECTRIC PUMP**

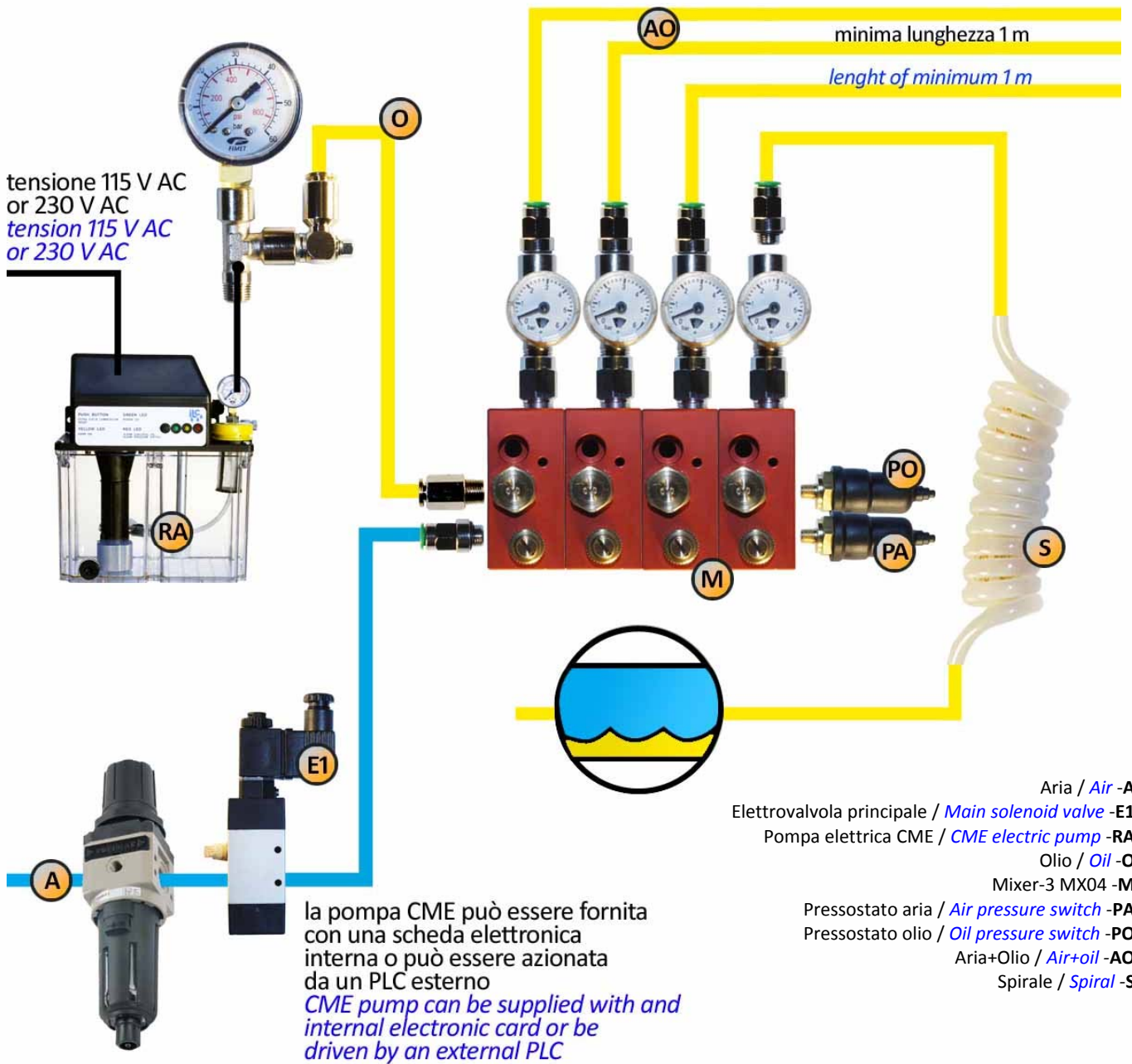



PER MANDRINO  
ELETTRIMANDRINO, VITI SENZA FINE  
E INGRANAGGI

FOR SPINDLE  
MOTOR SPINDLE, BALL SCREWS  
AND GEARS

**ESEMPIO DI SCHEMA  
CON POMPA ELETTRICA TRIFASE**

**LAYOUT EXAMPLE  
WITH TRIPHASE ELECTRIC PUMP**

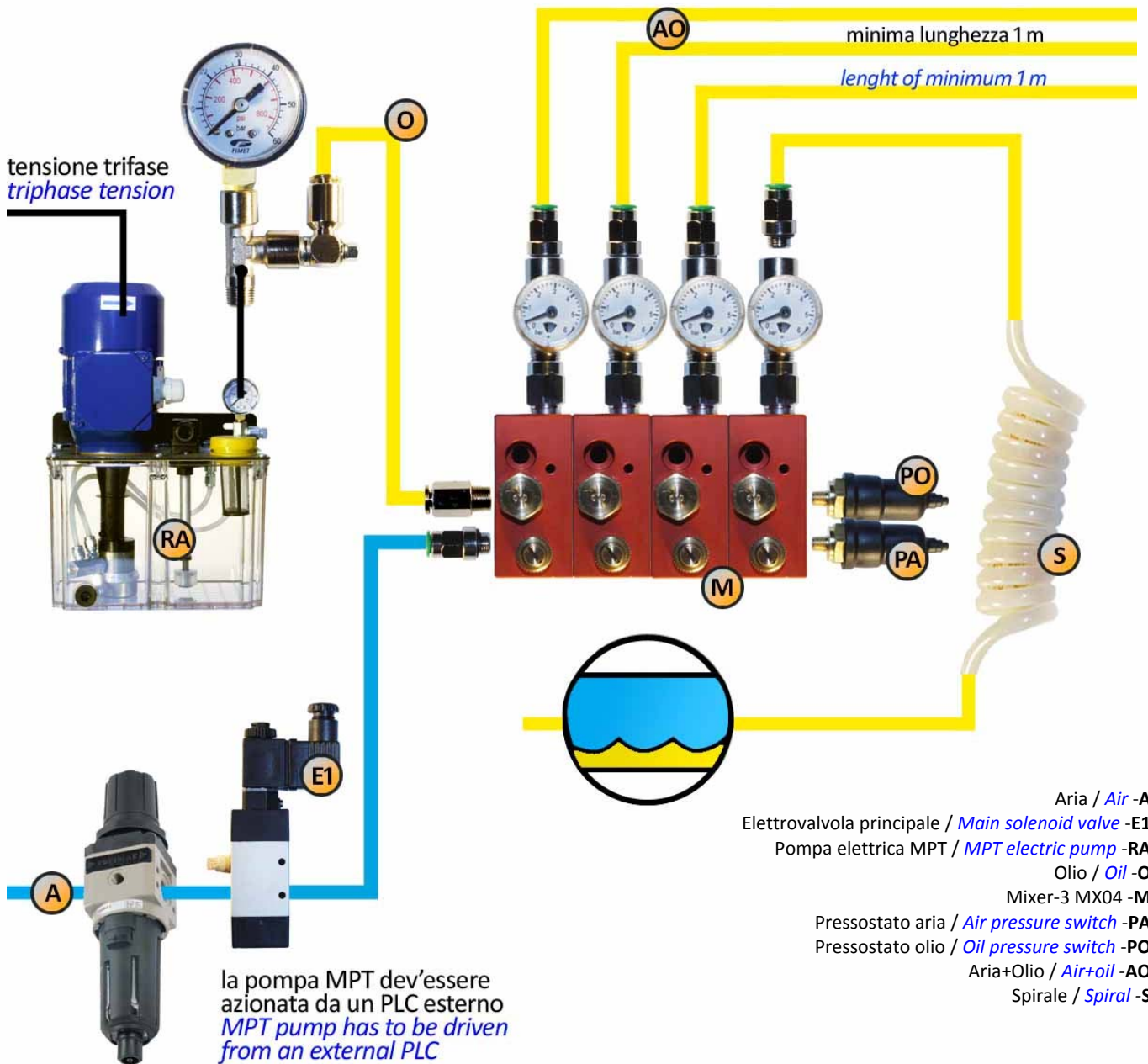

Cod.	descrizione	description	photo
14.655.1	Filtro aria	<i>Air filter</i>	
14.660.0	Elettrovalvola principale	<i>Main solenoid valve</i>	
14.660.1	Bobina 24 V DC	<i>Coil 24 V DC</i>	
14.660.2	Bobina 115 V AC	<i>Coil 115 V AC</i>	
14.660.3	Bobina 230 V AC	<i>Coil 230 V AC</i>	
14.660.4	Bobina 24 V AC	<i>Coil 24 V AC</i>	
14.663.5	Elettrovalvola per pompa	<i>Pump' solenoid valve</i>	
14.660.1	Bobina 24 V DC	<i>Coil 24 V DC</i>	
14.660.2	Bobina 115 V AC	<i>Coil 115 V AC</i>	
14.660.3	Bobina 230 V AC	<i>Coil 230 V AC</i>	
14.660.4	Bobina 24 V AC	<i>Coil 24 V AC</i>	
46.350.0	Manometro 0- 60	<i>Pressure gauge 0-60</i>	

46.700.4

Manometro 0-6

*Pressure gauge 0-6*





A92.106276

Raccordo "T" 1/8"G

*"T" fitting 1/8 "G*



03.205.0

Adattatore 1/8"G - 1/8"G

*Adapte 1/8 "G r*



03.256.0

Raccordo rapido dritto  
alta pressione  
tubo Ø6 1/8"G

*Straight high pressure  
push-in fitting  
tube Ø6 1/8 "G*



03.256.6

Raccordo rapido 90°  
alta pressione  
tubo Ø6 1/8"G

*Elbow high pressure  
push-in fitting  
tube Ø6 1/8 "G*



A92.106113  
A92.106074  
A92.106165

Raccordo rapido dritto Ø6 1/8"G  
Raccordo rapido dritto Ø8 1/8"G  
Raccordo rapido dritto Ø4 1/8"G

*Ø6 straight push-in 1/8 "G  
Ø8 straight push-in 1/8 "G  
Ø4 straight push-in 1/8 "G*



A92.106195  
A92.106110  
A92.106218

Raccordo rapido 90° Ø6 1/8"G  
Raccordo rapido 90° Ø8 1/8"G  
Raccordo rapido 90° Ø4 1/8"G

*Ø6 elbow push-in 1/8 "G  
Ø8 elbow push-in 1/8 "G  
Ø4 elbow push-in 1/8 "G*



A51.096055  
A92.127056

Tappo maschio 1/8"G  
O-Ring

*Male plug 1/8 "G  
O-Ring*



PER MANDRINO  
ELETTRIMANDRINO, VITI SENZA FINE  
E INGRANAGGI

FOR SPINDLE  
MOTOR SPINDLE, BALL SCREWS  
AND GEARS

49.055.0  
49.062.7  
49.062.9  
49.060.2

Cappuccio  
Pressostato olio 22 bar NA  
Pressostato olio 22 bar NC  
Pressostato aria 1 bar NA

*Cover*  
*Oil pressure switch set 22 bar NO*  
*Oil pressure switch set 22 bar NC*  
*Air pressure switch set 1 bar NO*



30.100.0  
30.120.0

Tubo  $\varnothing 4$   
Tubo  $\varnothing 6$

*Hose  $\varnothing 4$*   
*Hose  $\varnothing 6$*



A92.106544  
A92.106545

$\varnothing 6 - \varnothing 6$   
 $\varnothing 4 - \varnothing 4$

*$\varnothing 6 - \varnothing 6$*   
 *$\varnothing 4 - \varnothing 4$*



**Spirale**

*Spiral*

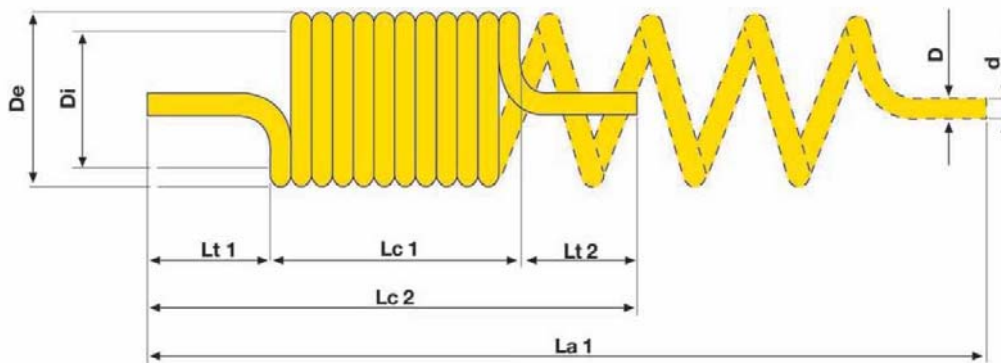

D	d	Cod.	De	Di	Lt1	Lt2	Lc1	Lc2	La1
4	2,5	30.165.1	50	42	100	100	190	390	3750
6	4	30.165.4	32	20	100	100	60	260	1000



**PER MANDRINO  
ELETTROMANDRINO, VITI SENZA FINE  
E INGRANAGGI**

**FOR SPINDLE  
MOTOR SPINDLE, BALL SCREWS  
AND GEARS**

**PRINCIPALI COMPONENTI**

**MAIN COMPONENTS**

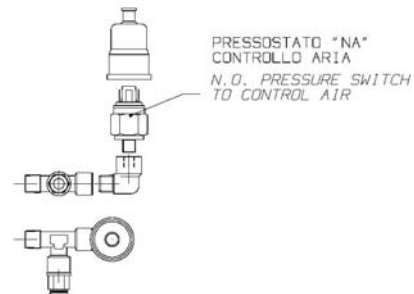
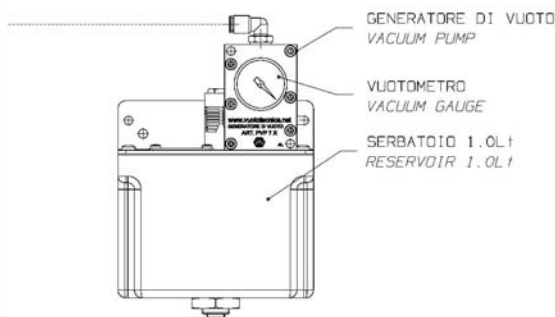
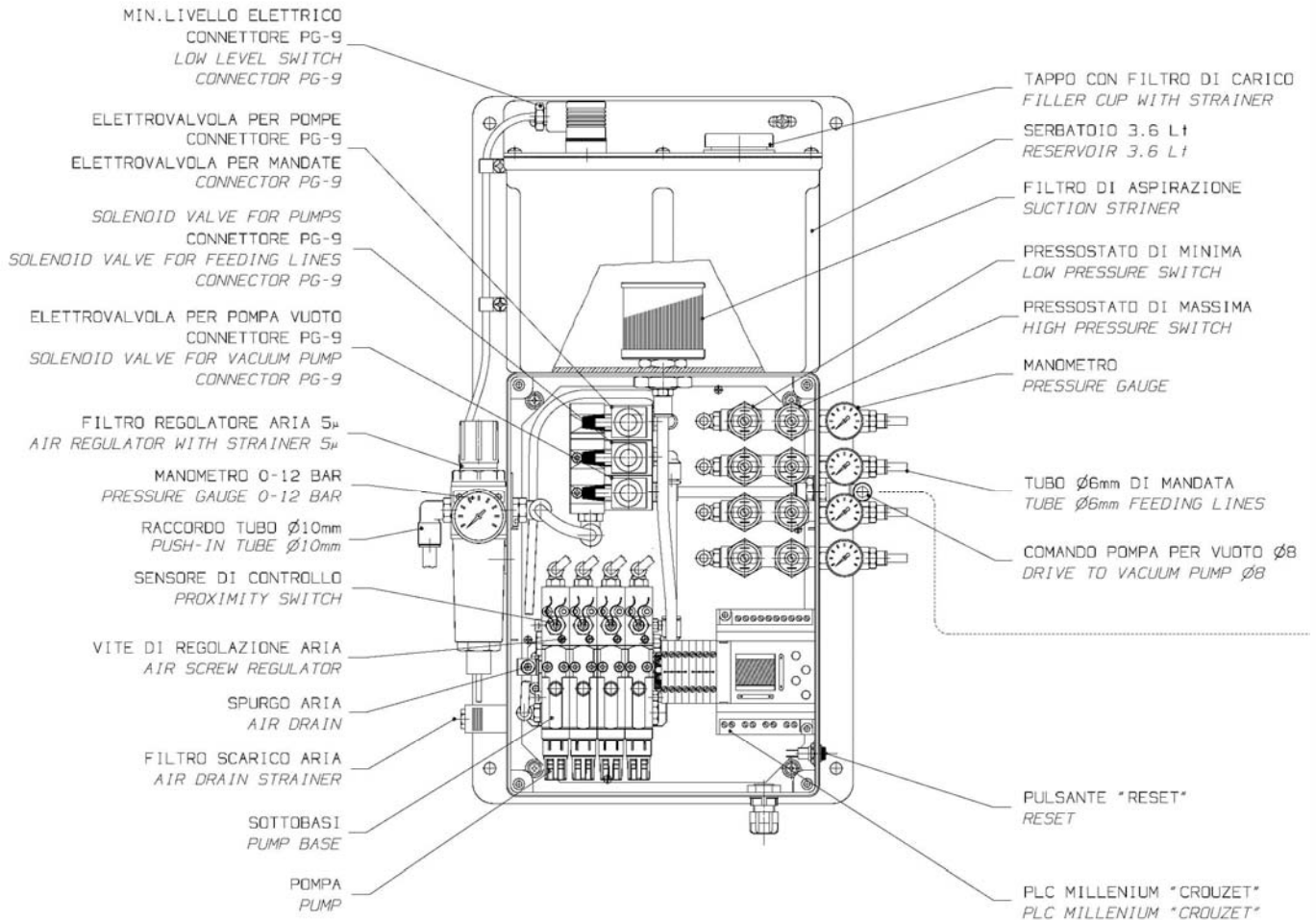



## FUNZIONAMENTO

Sono stati progettati per ottenere una precisa e corretta lubrificazione minimale di organi rotanti ad alte velocità e/o superfici a contatto con carichi elevati.

Il sistema aria-olio è un metodo di lubrificazione per l'ottenimento di portate minimali, che consiste nel rilascio di quantità molto piccole e ciclicamente dosate di lubrificante in un tubo di diametro opportuno, in cui scorre un flusso continuo d'aria compressa a bassa pressione.

A intervalli di tempo pre-determinati l'olio viene erogato da una micropompa pneumatica e immesso in una camera di miscelazione con l'aria.

Da qui, le gocce, sono trasportate lungo la superficie interna della tubazione di mandata in direzione del punto da lubrificare, dove sono erogate in forma di fine e continuo soffio d'aria umida d'olio.

Le micropompe pneumatiche vengono eccitate al termine del tempo di pausa impostato nel MINI-PLC interno o nel controllo della macchina. Ad ogni azionamento una piccolissima quantità di lubrificante viene aspirata dal serbatoio ed inviata alla camera di miscelazione situata nella sottobase della micropompe. Una volta raggiunta la camera di miscelazione l'olio viene scomposto in particelle grosse e trasportato nelle tubazioni di collegamento alle utenze finali mediante un flusso d'aria costante.

La pressione dell'aria nelle tubazioni di collegamento è mantenuta sotto controllo tramite il gruppo di controllo pressione posto nelle mandate delle unità. Un pressostato controlla costantemente il valore di pressione del flusso dell'aria nelle tubazioni secondarie (verifica di pressione minima = rottura tubazioni). Un ulteriore pressostato verifica che non si creino occlusioni nelle tubazioni finali (verifica di pressione massima = chiusura tubazione).

Il passaggio del lubrificante dalla micropompe alla camera di dosaggio è controllato mediante il sensore induttivo posto nella parte terminale della micropompe.

Tutte le unità sono inoltre dotate di sensore di minimo livello elettrico ed a richiesta possono essere equipaggiate con un MINI-PLC in grado di inviare i comandi di pausa e lavoro e raccogliere tutti i segnali di eventuali anomalie. Questo segnale può inoltre essere trasmesso a distanza.

La pompa del vuoto serve a recuperare eventuali depositi d'olio dall'interno dell'elettromandrino.



## OPERATION

*They can be used to lubricate in the correct way high-speed bearings and surfaces in contacts with high loads.*

*The air-oil system is a method of lubrication for a minimal flow obtainment, which depends on a minimal release of quantity and the lubrication is frequently measured out in a suitable tube diameter, in which flows compressed air under minimal pressure. By predetermined time intervals the oil will be distributed and will be put on to the mixing block with compressed air.*

*From here, the feeded drops are conveyed lengthways towards the point to be lubricating, where they are supplied like a thin and continuous breathing of a humid oil-air mixture.*

*The micro pneumatic pumps are switched on at the end of the pause time set with the PLC "Millenium" (or with the machine PLC). They feed a metered quantity of oil from the reservoir to the mixing chambers of the pump bases. The oil is transported to the friction points by the continuous flow of compressed air.*

*The air pressure in the delivery lines is monitored from the PLC "Millenium" by mean of pressure switches.*

*The oil in the delivery line is monitored from the PLC "Millenium" by mean of inductive sensors.*

*The oil level in the reservoir is monitored from the PLC "Millenium" by mean of a float switch.*

*The PLC "Millenium" will indicate a fault if the air pressure required (the secondary line is broken) is not reached or if is too high (the secondary line is plugged), if the oil is not going in the delivery line or if the oil falls below the minimum level in the reservoir.*

*Of course it is possible to check all the fault by mean of the machine PLC.*

*In case has to be recovered air/oil from the spindle it will be necessary to use a vacuum pump.*

**UNITÀ CON SCATOLA DI PROTEZIONE**

**UNIT WITH BOX**

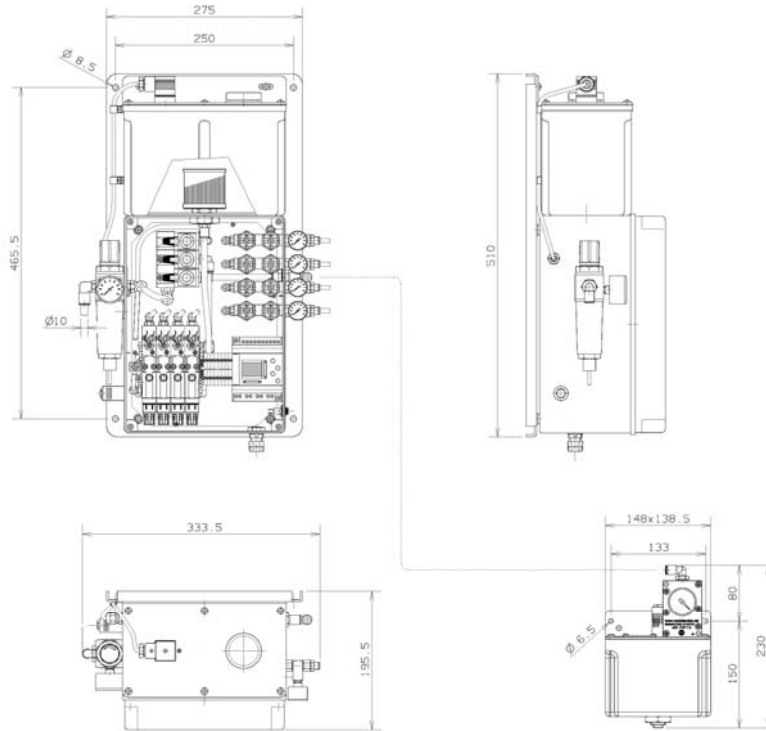

CARATTERISTICHE		FEATURES	
N.MICROPOMPE	DA 1 A 4	PUMPS NUMBER	FROM 1 TO 4
PORTATA	DA 1.5 A 41 MM <sup>3</sup> /CICLO	DISCHARGE	FROM 1.5 TO 41 MM <sup>3</sup> /STROKE
FREQ. CICLI MAX	1 OGNI 5 SECONDI	STROKES	1 EVERY 5 SECONDS
LUBRIFICANTI	DA ISO VG-32 A ISO VG-68	LUBRICANTS	FROM ISO VG-32 TO ISO VG-100
SERBATOIO	NYLON 3.6 L	RESERVOIR	NYLON 3.6 L
MIN. LIV. ELETTRICO	1 A 250 V AC – 200 V DC 50 W	LOW LEVEL SWITCH	1 A 250 V AC – 200 V DC 50 W
FILTRO DI CARICO	250 µ	REFILL STRAINER	250 µ
FILTRO ASPIRAZIONE	10 µ	SUCTION STRAINER	10 µ
TEMPERATURA	DA 0° C A 60 °C	TEMPERATURE	FROM 0° C TO 60 °C
TUBAZIONI MANDATA	6x4 MM 12 M LUNG. MAX	DELIVERY TUBE	6x4 MM 12 M MAX LENGTH

**CODICE ORDINAZIONE – CODES FOR ORDER**

CODICE - CODE	MANDATE – DELIVERIES
70.500.1	1
70.500.2	2
70.500.3	3
70.500.4	4

Al fine di completare l'unità bisogna ordinare un elemento di controllo per ogni singola uscita. Vedere esempi a pagina 24.

To complete the system have to be ordered an inductive sensor and a pressure switch for each outlet. See page 24 for example.

A richiesta sono disponibili altre versioni per poter soddisfare tutte le esigenze.

On request can be supplied different versions to satisfy all the possible applications.



**UNITÀ A GIORNO DA 1 A 4 MANDATE**

**UNIT WITHOUT BOX UNTIL 4 OUTLETS**

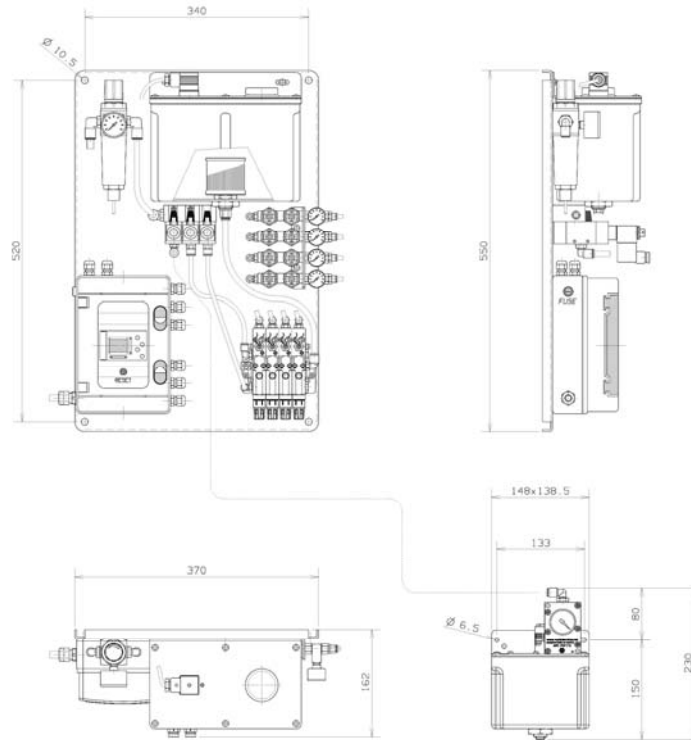

CARATTERISTICHE		FEATURES	
N.MICROPOMPE	DA 1 A 4	PUMPS NUMBER	FROM 1 TO 4
PORTATA	DA 1.5 A 41 MM <sup>3</sup> /CICLO	DISCHARGE	FROM 1.5 TO 41 MM <sup>3</sup> /STROKE
FREQ. CICLI MAX	1 OGNI 5 SECONDI	STROKES	1 EVERY 5 SECONDS
LUBRIFICANTI	DA ISO VG-32 A ISO VG-68	LUBRICANTS	FROM ISO VG-32 TO ISO VG-100
SERBATOIO	NYLON 3.6 L	RESERVOIR	NYLON 3.6 L
MIN. LIV. ELETTRICO	1 A 250 V AC – 200 V DC 50 W	LOW LEVEL SWITCH	1 A 250 V AC – 200 V DC 50 W
FILTRO DI CARICO	250 $\mu$	REFILL STRAINER	250 $\mu$
FILTRO ASPIRAZIONE	10 $\mu$	SUCTION STRAINER	10 $\mu$
TEMPERATURA	DA 0° C A 60 °C	TEMPERATURE	FROM 0° C TO 60 °C
TUBAZIONI MANDATA	6x4 MM 12 M LUNG. MAX	DELIVERY TUBE	6x4 MM 12 M MAX LENGTH

**CODICE ORDINAZIONE – CODES FOR ORDER**

CODICE - CODE	MANDATE – DELIVERIES
70.504.1	1
70.504.2	2
70.504.3	3
70.504.4	4

Al fine di completare l'unità' bisogna ordinare un elemento di controllo per ogni singola uscita. Vedere esempi a pagina 24.

A richiesta sono disponibili altre versioni per poter soddisfare tutte le esigenze.

To complete the system have to be ordered an inductive sensor and a pressure switch for each outlet. See page 24 for example.

On request can be supplied different versions to satisfy all the possible applications.





**CODICI DI ORDINAZIONE PER ELEMENTI DI CONTROLLO SISTEMA**

CODE	DESCRIZIONE
70.510.0	CONTROLLO DI FLUSSO INDUTTIVO NPN
70.510.1	CONTROLLO DI FLUSSO INDUTTIVO PNP
70.510.2	GRUPPO CONTROLLO MINIMA PRESSIONE ARIA LINEA SECONDARIA
14.669.9	POMPA VUOTO CON SERBATOIO L 0.35 PER UNITA' CON SCATOLA DI PROTEZIONE
14.669.8	POMPA VUOTO CON SERBATOIO L 0.35 PER UNITA' A GIORNO
70.510.5	GRUPPO CONTROLLO MASSIMA E MINIMA PRESSIONE ARIA LINEA SECONDARIA
70.510.3	PLC "MILLENIUM" 24 V DC 6 IN - 4 USCITE PER UNITA' CON SCATOLA DI PROTEZIONE
70.510.4	PLC "MILLENIUM" 24 V DC 12 IN - 8 USCITE
70.510.6	PLC "MILLENIUM" 24 V DC 6 IN - 4 USCITE PER UNITA' A GIORNO
70.510.9	PRESSOSTATO "NA" PER CONTROLLARE L'ARIA PRINCIPALE

**CODES FOR ORDER ELEMENTS TO CONTROL THE SYSTEM**

CODE	DESCRIPTION
70.510.0	BLOCK TO CONTROL OIL FLOW WITH INDUCTIVE SENSOR NPN
70.510.1	BLOCK TO CONTROL OIL FLOW WITH INDUCTIVE SENSOR PNP
70.510.2	BLOCK TO CONTROL LOW AIR PRESSURE WITH PRESSURE SWITCH
14.669.9	VACUUM PUMP COMPLETE OF 0.35 L RESERVOIR FOR BOX VERSION
14.669.8	VACUUM PUMP COMPLETE OF 0.35 L RESERVOIR FOR WITHOUT BOX VERSION
70.510.5	BLOCK TO CONTROL LOW AND HIGH AIR PRESSURE WITH PRESSURE SWITCHES
70.510.3	PLC "MILLENIUM" 24 V DC 6 IN - 4 OUT FOR BOX VERSION
70.510.4	PLC "MILLENIUM" 24 V DC 12 IN - 8 OUT
70.510.6	PLC "MILLENIUM" 24 V DC 6 IN - 4 OUT FOR WITHOUT BOX VERSION
70.510.9	"NO" PRESSURE SWITCH TO CONTROL MAIN AIR

**COME ORDINARE**

**ESEMPIO N. 1**

Unità spindle con scatola di protezione per due punti completa di controllo olio, controllo minima pressione aria, controllo massima pressione aria e plc. Senza pompa del vuoto

**CODICI DA ORDINARE**

N. 1 70.500.2  
N. 2 70.510.0 O 70.510.1  
N. 2 70.510.5  
N. 1 70.510.3

**ESEMPIO N. 2**

Unità spindle a giorno per quattro punti completa di controllo olio, controllo minima pressione aria, plc e pompa del vuoto

**CODICI DA ORDINARE**

N. 1 70.504.4  
N. 4 70.510.0 O 70.510.1  
N. 4 70.510.2  
N. 1 70.510.6  
N. 1 14.669.8

**HOW TO ORDER**

**EXAMPLE N. 1**

Unit with box for two points complete with oil flow control, low and air pressure control and plc. Without vacuum pump

**CODES HAVE TO BE ORDERED**

N. 1 70.500.2  
N. 2 70.510.0 OR 70.510.1  
N. 2 70.510.5  
N. 1 70.510.3

**EXAMPLE N. 2**

Unit without box for four points complete with oil flow control, low air pressure control, plc and vacuum pump

**CODES TO BE ORDERED**

N. 1 70.504.4  
N. 4 70.510.0 O 70.510.1  
N. 4 70.510.2  
N. 1 70.510.6  
N. 1 14.669.8



**MICROPOMPA PNEUMATICA DI DOSAGGIO**

**POSITIVE DISPLACEMENT METERING PNEUMATIC  
PUMP**

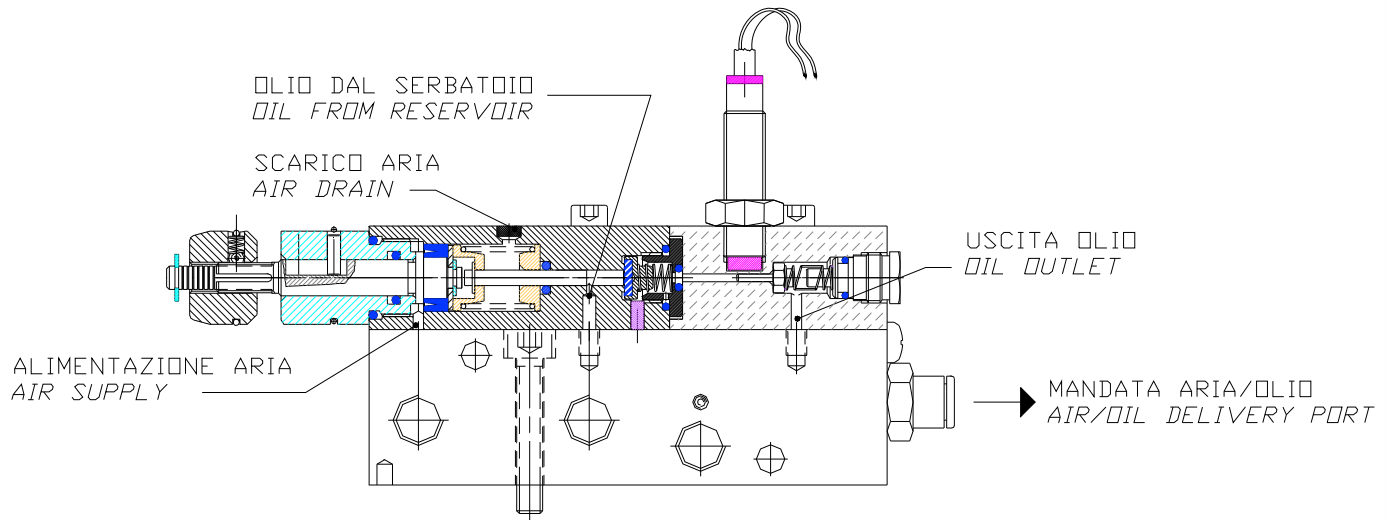

**FUNZIONAMENTO**

**OPERATION**

Le micropompe di dosaggio sono unità pneumatiche predisposte per l'erogazione di piccole quantità di lubrificante con frequenze di funzionamento molto rapide. L'attivazione avviene tramite aria compressa ad una pressione di 5 – 10 bar (75 – 150 psi). Il flusso d'aria raggiunge il pistone pneumatico che avanzando nel cilindro aziona il pistoncino idraulico. Durante questa fase si avrà l'erogazione del lubrificante attraverso la valvola di mandata. Quando il flusso s'interrompe la molla di richiamo riporta il pistone nella posizione di partenza. Durante questa fase avviene l'aspirazione del lubrificante dal serbatoio che viene introdotto nella camera di dosaggio. La micropompa è pronta per un nuovo ciclo.

*The drive of the unit is carried out by a simple-action pneumatic piston that is controlled by compressed air with a pressure from 5 bar (75 psi) to 10 bar (150 psi). When the air is turned on the piston moves and there will be an exact amount of lubricant in the discharge port. When the air is turned off the piston comes back by means of a spring and the metering chamber will fill of lubricant. The pump is ready for a new stroke.*

Le frequenze di funzionamento possono essere impostate dal PLC della macchina o per mezzo del nostro PLC. Sugeriamo di non usare frequenze inferiori a 6/ora.

*The strokes per second, per minute or per hour can be adjusted from the machine PLC or by mean of our PLC. We suggest to have not cycles less than 6/hour.*

La portata di lubrificante può essere regolata per mezzo di un pomolo da 1.5 mm<sup>3</sup> a 41 mm<sup>3</sup>.

*The lubricant discharge can be adjusted by means of the pump manual ratchet adjuster to give a discharge between 1.5 mm<sup>3</sup> and 41 mm<sup>3</sup> per stroke.*

Al fine di controllare il passaggio dell'olio con il sensore induttivo la minima portata non deve essere inferiore a 5 mm<sup>3</sup>.

*To check the oil flow by mean of the inductive sensor the pump discharge have not to be less than 5 mm<sup>3</sup>*



## REGOLAZIONE DELLA PORTATA DEL CICLO

RUOTARE IL POMOLO IN SENSO ORARIO PER RIDURRE  
LA QUANTITA' DI OLIO ED IN SENSO ANTIORARIO PER  
INCREMENTARLA.

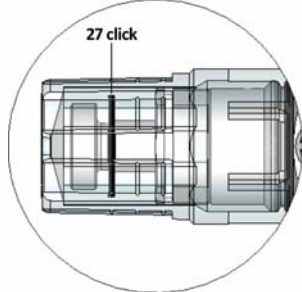
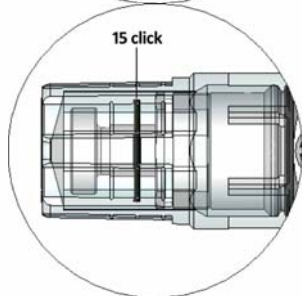
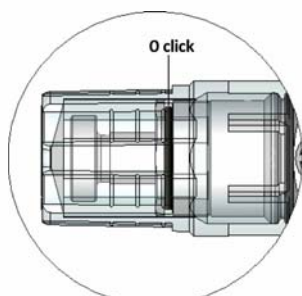

## HOW TO ADJUST THE DISCHARGE PER STROKE

TURNING THE ADJUSTER CLOCKWISE WILL DECREASE THE  
PUMP DISCHARGE AND TURNING THE ADJUSTER ANTI-  
CLOCKWISE WILL INCREASE THE PUMP DISCHARGE.

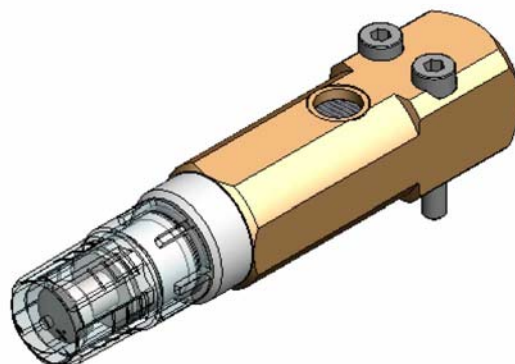

SCATTI INCREMENTS	PORTATA / CICLO DISCHARGE / CYCLE
CLICK 0	39,00
CLICK 1	37,23
CLICK 2	35,47
CLICK 3	33,70
CLICK 4	31,93
CLICK 5	30,16
CLICK 6	28,40
CLICK 7	26,63
CLICK 8	24,86
CLICK 9	23,10
CLICK 10	21,33
CLICK 11	19,56
CLICK 12	17,79
CLICK 13	16,03
CLICK 14	14,26
CLICK 15	12,49
CLICK 16	10,73
CLICK 17	8,96
CLICK 18	7,19
CLICK 19	5,42
CLICK 20	3,66
CLICK 21	1,89
CLICK 22	0,12
CLICK 23	0,00
CLICK 24	0,00
CLICK 25	0,00
CLICK 26	0,00
CLICK 27	0,00



PER MANDRINO  
ELETTRIMANDRINO, VITI SENZA FINE  
E INGRANAGGI

FOR SPINDLE  
MOTOR SPINDLE, BALL SCREWS  
AND GEARS

**SOTTO-BASE POMPA PER MISCELAZIONE ARIA-OLIO**

**PUMP BASE TO MIX AIR AND OIL**

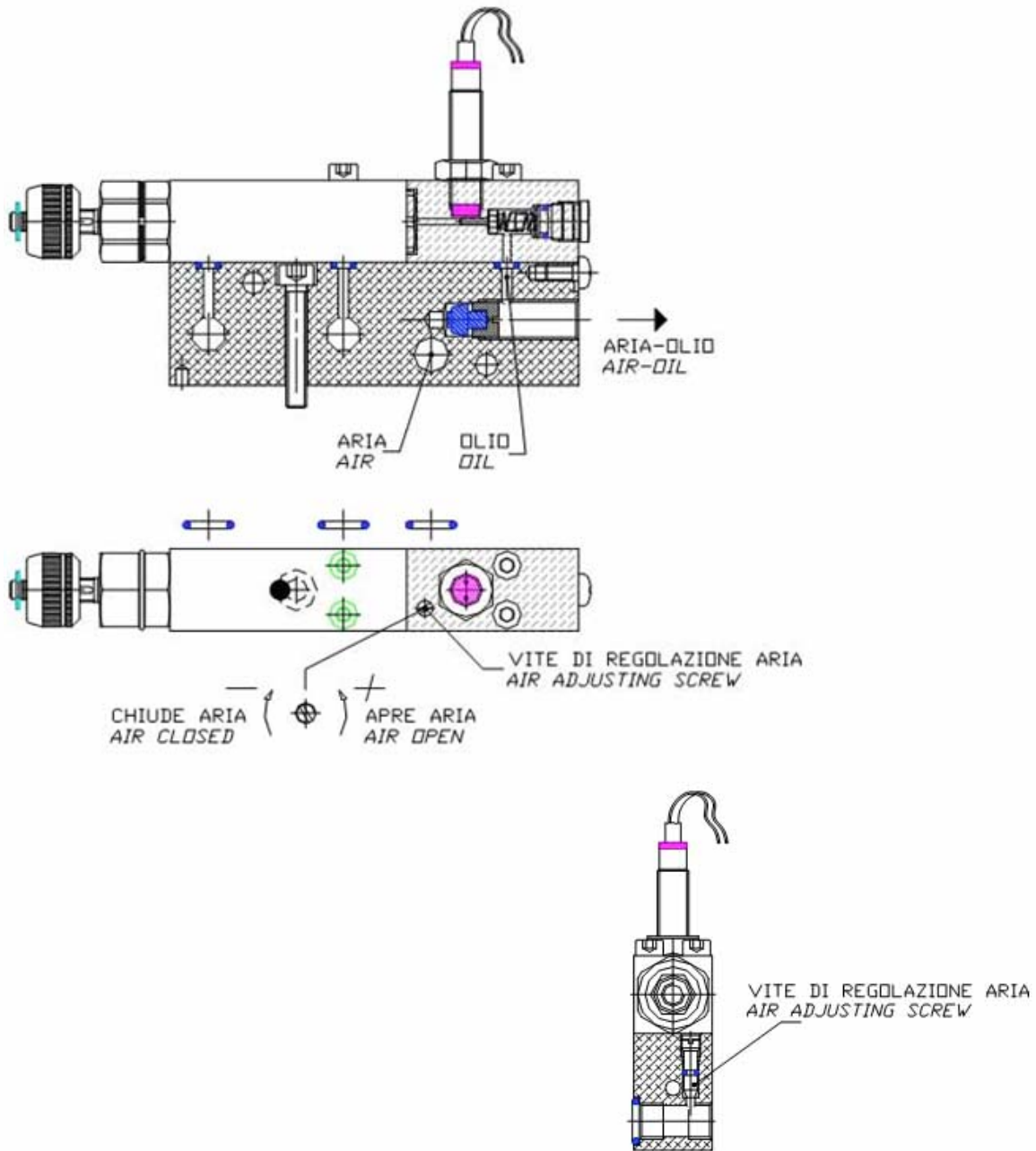

## SENSORE INDUTTIVO PER CONTROLLO FLUSSO LUBRIFICANTE

## INDUCTIVE SENSOR FOR MONITORING LUBRICANT

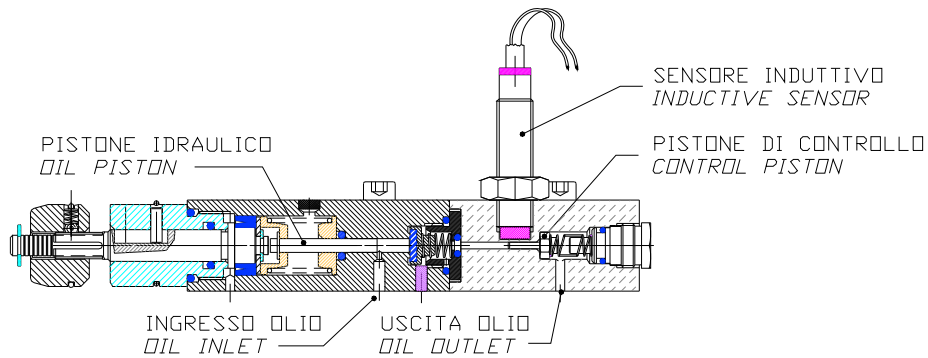

Il sensore di controllo flusso lubrificante permette una reale verifica dell'effettivo passaggio dell'olio dosato verso la camera di miscelazione.

la rilevazione viene effettuata tramite il pistoncino di controllo posizionato al di sotto del sensore induttivo che ad ogni intervento del sistema effettua un movimento di avvicinamento alla valvola di mandata. Questo spostamento genera un segnale elettrico del sensore induttivo. Un funzionamento a vuoto o parziale della pompa non permette la regolare corsa del pistoncino con conseguente invio di un segnale d'allarme.

Durante la fase d'avviamento dell'impianto si potranno avere delle segnalazioni d'allarme dovute alla presenza d'aria nella camera.

La minima quantità di olio che si riesce a controllare è 5 mm<sup>3</sup>

*Via the control piston situated under the sensor it is possible to detect the flow of lubricant to the reaction chamber. The control piston is moved off its seat by oil being delivered via the oil piston and allowing oil to flow into the reaction chamber closing the sensor switch. Once this has occurred spring pressure re-seats the control piston opening the sensor switch and the system is working correctly. If there is no oil delivery from the oil piston the control piston remain in its seated position and, due to the sensor switch not closing, the system alarm is activated.*

*During the prime phase it will be possible to have alarm.*

*The minimum oil quantity can be checked is 5 mm<sup>3</sup>.*

### CARATTERISTICHE

### FEATURES

TENSIONE	6-30 V DC
CORRENTE IN USCITA	MAX 200 Ma
CORRENTE	< 12 Ma
TEMPERATURA	- 25 C / + 70 C
PROTEZIONE	IP 67
CORPO SENSORE	STAINLESS STEEL
CAVI SENSORE	3x014 mm <sup>2</sup> PVC

VOLTAGE	6-30 V DC
OUTLET CURRENT	MAX 200 Ma
CURRENT	< 12 Ma
TEMPERATURE RANGE	- 25 C / + 70 C
PROTECTION	IP 67
CASING	STAINLESS STEEL
CABLE	3x014 mm <sup>2</sup> PVC

### SCHEMA ELETTRICO

### ELECTRICAL WIRING

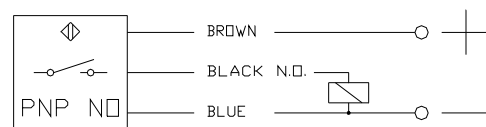
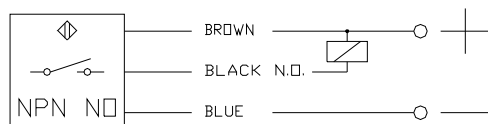

**GRUPPO DI CONTROLLO PRESSIONE MINIMA  
DELL'ARIA NELLA LINEA PRINCIPALE**

**PRESSURE SWITCH TO CHECK AIR LOW FLOW IN  
THE MAIN LINE**

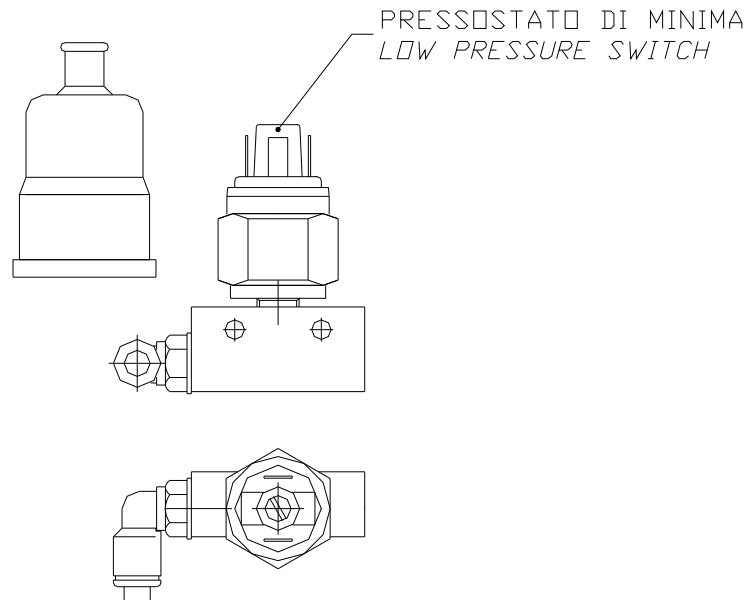

Controlla il valore della pressione dell'aria all'uscita dell'elettrovalvola che invia aria all'impianto. Il contatto normalmente aperto è attivato dal passaggio dell'aria proveniente dall'elettrovalvola ed un abbassamento del valore al di sotto di quanto impostato provoca un ritorno allo stato di partenza del contatto ed un conseguente invio del segnale d'allarme.

*This is situated after the solenoid valve sending air in the delivery lines. The switch is normally open and the pressure flow of air closes the contact. If there is no airflow the switch changes to open thus activating the system alarm.*

**CARATTERISTICHE**

**FEATURES**

PRESSIONE ESERCIZIO	2 – 10 BAR
SETTATO	3.5 BAR
CONTATTO	NORMALMENTE APERTO
TENSIONE MAX	220 V AC
POTENZA MAX	100 VA
CORRENTE	0.5 RESISTIVA 0.25 INDUTTIVA
TEMPERATURA	DA -5 °C A + 60 °C
PROTEZIONE	IP 54
CICLI MASSIMI	200/1'

OPERATING PRESSURE	2 – 10 BAR
FACTORY SET	3.5 BAR
CONTACT	NORMALLY OPEN
MAX VOLTAGE	220 V AC
MAX POWER	100 VA
CURRENT	0.5 RESISTIVE 0.25 INDUCTIVE
WORKING TEMPERATURE	FROM -5 °C TO + 60 °C
PROTECTION	IP 54
MAX CYCLES	200/1'

**Importante:**

Il valore settato non può essere variato. A richiesta sono disponibili pressostati tarati secondo le esigenze del cliente.

**Important:**

*The factory set values cannot be changed. On request we can supply pressure switches set on the customers need.*



**GRUPPO DI CONTROLLO PRESSIONE MINIMA  
DELL'ARIA**

**PRESSURE SWITCH TO CHECK AIR LOW FLOW**

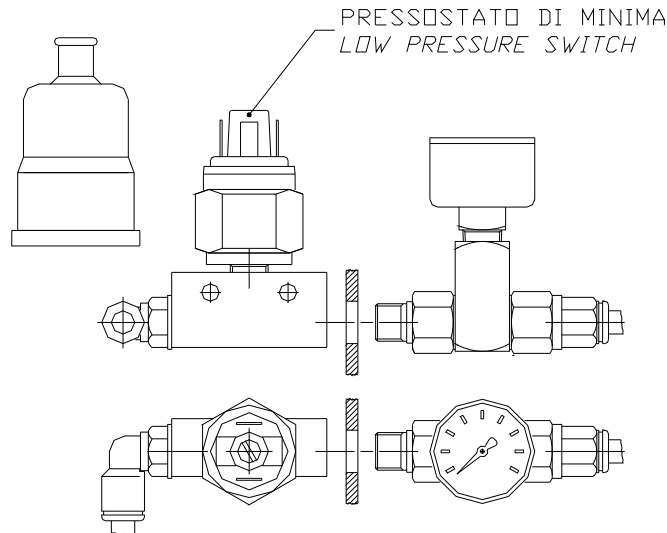

Installato direttamente nelle mandate delle linee secondarie controlla il valore della pressione dell'aria nelle tubazioni di collegamento alle utenze finali. Il contatto normalmente aperto è attivato dal passaggio dell'aria proveniente dall'elettrovalvola ed un abbassamento del valore al disotto di quanto impostato provoca un ritorno allo stato di partenza del contatto ed un conseguente invio del segnale d'allarme.

*This is situated on the delivery line. The switch is normally open and the pressure flow of air closes the contact. If there is no air flow the switch changes to open thus activating the system alarm.*

**CARATTERISTICHE**

PRESSIONE ESERCIZIO	0.15 – 2 BAR
SETTATO	1 BAR
CONTATTO	NORMALMENTE APERTO
TENSIONE MAX	220 V AC
POTENZA MAX	100 VA
CORRENTE	0.5 RESISTIVA 0.25 INDUTTIVA
TEMPERATURA	DA -5 °C A + 60 °C
PROTEZIONE	IP 54
CICLI MASSIMI	200/1'

**FEATURES**

OPERATING PRESSURE	0.15 – 2 BAR
FACTORY SET	1 BAR
CONTACT	NORMALLY OPEN
MAX VOLTAGE	220 V AC
MAX POWER	100 VA
CURRENT	0.5 RESISTIVE 0.25 INDUCTIVE
WORKING TEMPERATURE	FROM -5 °C TO + 60 °C
PROTECTION	IP 54
MAX CYCLE	200/1'

**Importante:**

Il valore settato non può essere variato. A richiesta sono disponibili pressostati tarati secondo le esigenze del cliente.

**Important:**

*The factory set values cannot be changed. On request we can supply pressure switches set on the customers need.*



**GRUPPO DI CONTROLLO MINIMA E MASSIMA  
PRESSIONE D'ARIA**

**PRESSURE SWITCHES TO CHECK AIR LOW AND HIGH  
FLOW**

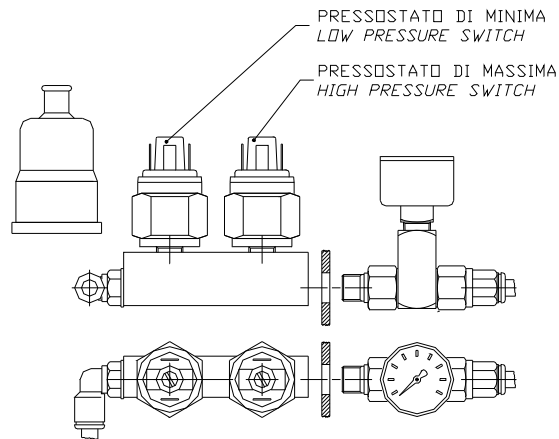

Installati direttamente nelle mandate delle linee secondarie controllano il valore della pressione dell'aria nelle tubazioni di collegamento alle utenze finali. Il pressostato per controllare la mancanza di aria ha il contatto normalmente aperto. Il pressostato per controllare l'aria alta ha il contatto normalmente chiuso. In caso di alta o bassa aria si provoca una variazione dei contatti con un conseguente invio del segnale d'allarme

*These are situated on the delivery line. The switch to check the low air is normally open and the pressure flow of air closes the contact. The switch to check the high air is normally closed and the high-pressure flow of air open the contact. If there is no air flow the switch changes to open thus activating the system alarm. If there is an high air flow the switch changes to open thus activating the system alarm*

**CARATTERISTICHE**

**FEATURES**

PRESSOSTATO ARIA MINIMA	0.15 – 2 BAR
CONTATTO	NORMALMENTE APERTO
SETTATO	1 BAR
PRESSOSTATO ARIA ALTA	2 – 10 BAR
CONTATTO	NORMALMENTE CHIUSO
SETTATO	3.5 BAR
TENSIONE MAX	220 V AC
POTENZA MAX	100 VA
CORRENTE	0.5 RESISTIVA 0.25 INDUTTIVA
TEMPERATURA	DA -5 °C A + 60 °C
PROTEZIONE	IP 54
CICLI MASSIMI	200/1'

PRESSURE SWITCH LOW AIR	0.15 – 2 BAR
CONTACT	NORMALLY OPEN
FACTORY SET	1 BAR
PRESSURE SWITCH HIGH AIR	2 – 10 BAR
CONTACT	NORMALLY CLOSED
FACTORY SET	3.5 BAR
MAX VOLTAGE	220 V AC
MAX POWER	100 VA
CURRENT	0.5 RESISTIVE 0.25 INDUCTIVE
WORKING TEMPERATURE	FROM -5 °C TO + 60 °C
PROTECTION	IP 54
MAX CYCLE	200/1'

**Importante:**

Il valore settato non può essere variato. A richiesta sono disponibili pressostati tarati secondo le esigenze del cliente.

**Important:**

*The factory set values cannot be changed. On request we can supply pressure switches set on the customers need.*





**POMPA VUOTO CON SERBATOIO  
A72.079417**

**VACUUM PUMP WITH RESERVOIR  
A72.079417**

Nel caso sia necessario recuperare automaticamente eventuali depositi d'olio dall'interno dell'elettromandrino e' possibile equipaggiare le unita' spindle di una pompa per vuoto. Questo apparecchio e' completo di serbatoio silenziatore filtro per aria e manometro.

*Vacuum generators operate using the Venturi principle and thanks to a special silencer installed in their outlet, they are particularly noiseless. They are currently equipped with a vacuum gauge for the direct reading of the vacuum degree.*

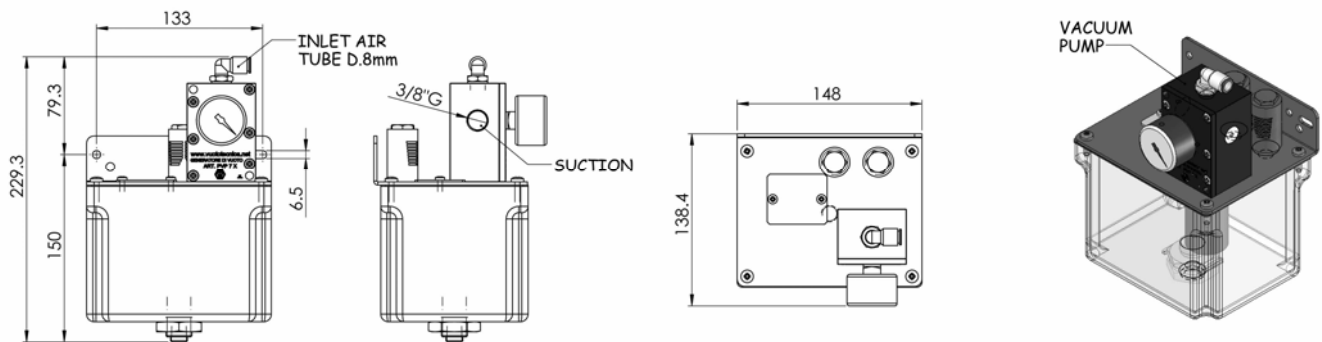

CARATTERISTICHE – FEATURES				
PRESSIONE DI ESERCIZIO <i>WORKING PRESSURE</i>	Bar	4	5	6
VUOTO FINALE <i>FINAL VACUUM</i>	-Kpa	60	73	85
	Mbar	400	270	150
CONSUMO ARIA <i>AIR CONSUMPTION</i>	NI/s	2.3	2.7	3.2
QUANTITA' D'ARIA ASPIRATA <i>SUCKED AIR CAPACITY</i>	Cum/h Mc/h	7.2	7.7	8.2
TEMPERATURA ESERCIZIO <i>WORKING TEMPERATURE</i>	°C		- 20 / + 80	

I valori indicati sono riferiti a normali condizioni di pressione atmosferica (1013 mbar) e con pressione di lavoro costante.

*All the vacuum values shown in the table are valid at the normal atmospheric pressure of 1013 mbar and obtained with a constant working pressure.*





## SCHEMA ELETTRICO PER LE UNITA' CHE VENGONO CONSEGNATE SENZA IL PLC

## ELECTRICAL WIRING FOR UNITS PRODUCED WITHOUT THE PLC

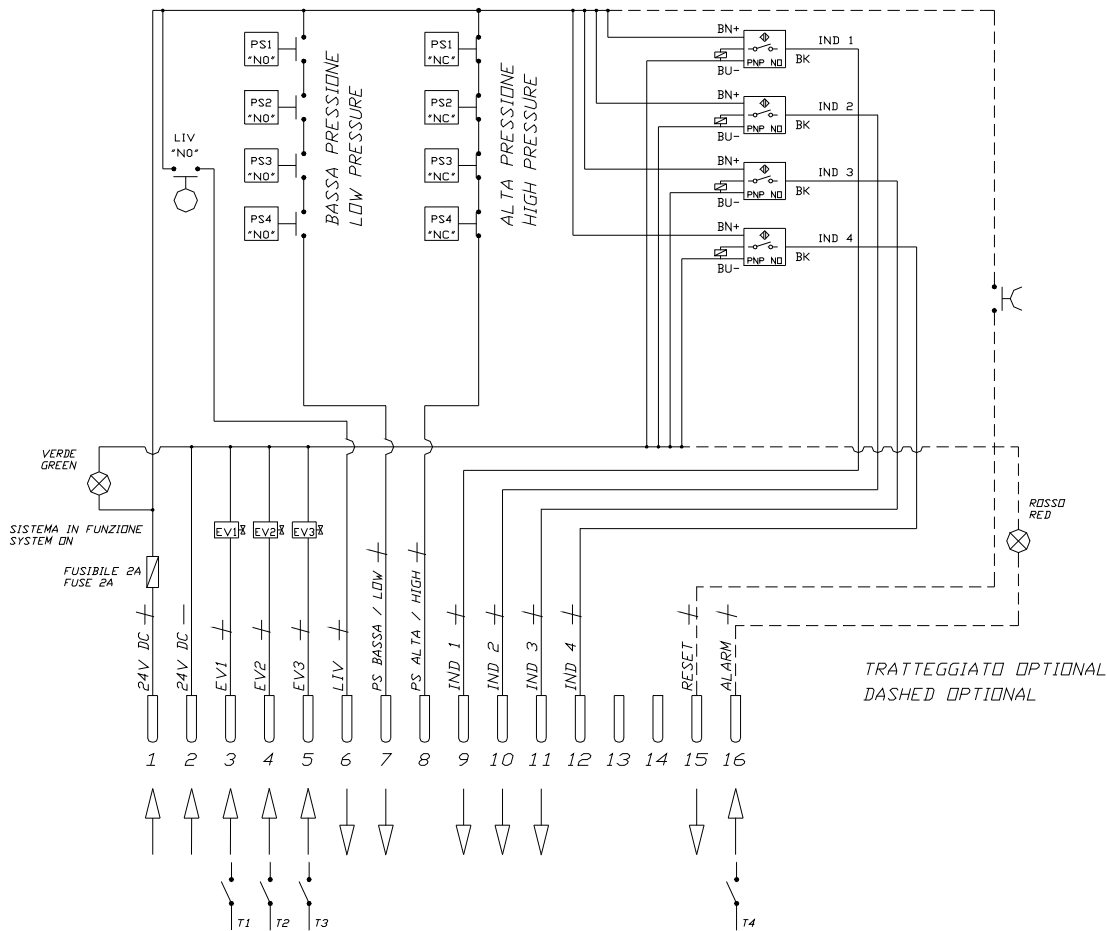

EV1=ARIA MICROPOMPE / MICROPUMPS AIR  
EV2=ARIA USCITE / OUTLETS AIR  
EV3=ARIA POMPA VUOTO / VACUUM PUMP AIR

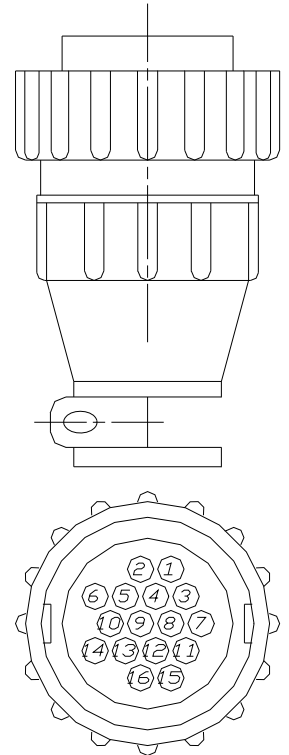

PER MANDRINO  
ELETTROMANDRINO, VITI SENZA FINE  
E INGRANAGGI

FOR SPINDLE  
MOTOR SPINDLE, BALL SCREWS  
AND GEARS

**ESEMPIO DI SCHEMA  
CON MICROPOMPE PNEUMATICHE**

**LAYOUT EXAMPLE  
WITH MICRO PNEUMATIC PUMPS**

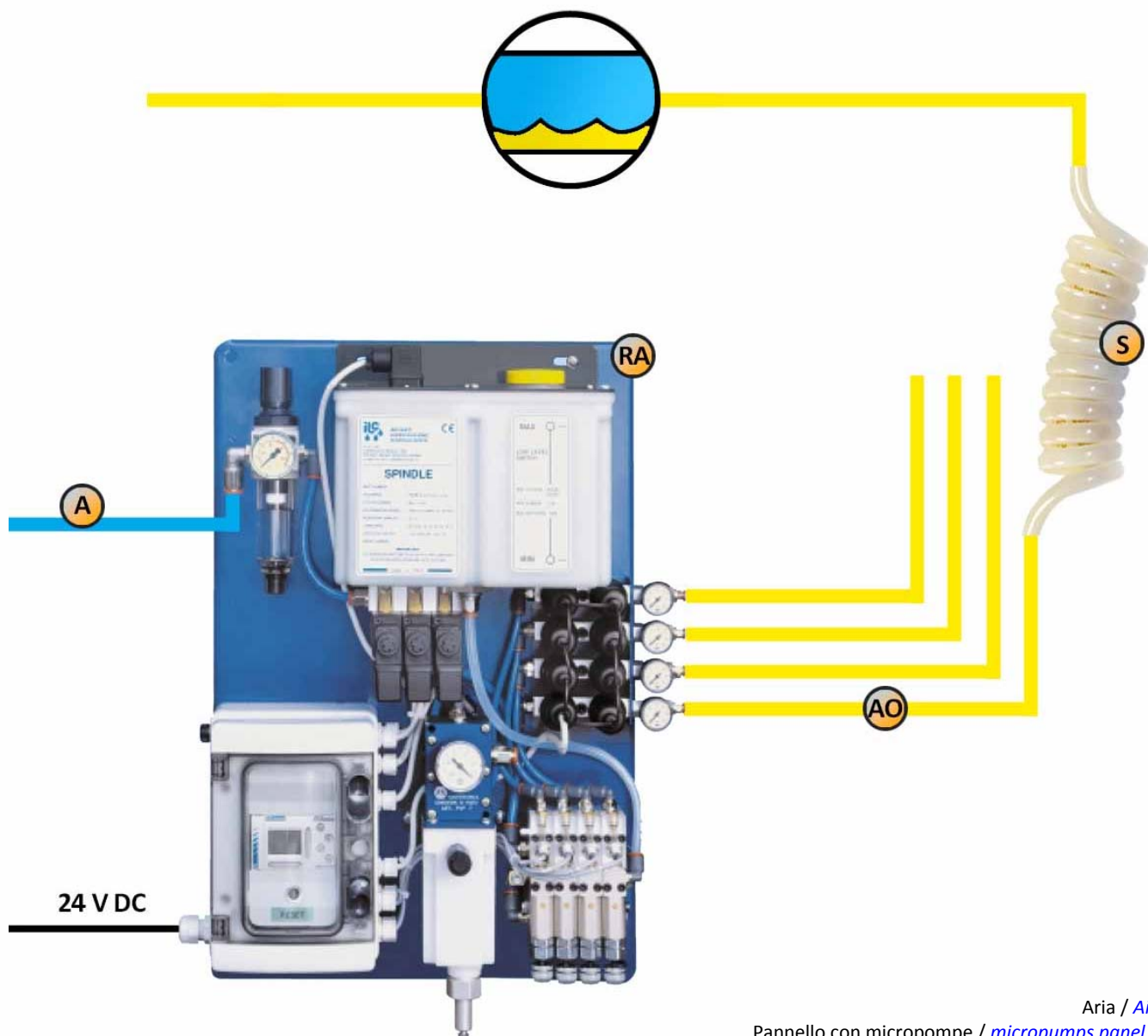

Aria / Air -A  
Pannello con micropompe / *micropumps panel* -RA  
Aria+Olio / Air+oil -AO  
Spirale / *Spiral* -S





## NOTES

A large yellow oil droplet graphic is centered on a notepad background with horizontal lines. The notepad has a tab at the top.

ILC LUBRICATION SYSTEMS

